

## NOTICE TO BIDDERS

**Warren County Schools, Owner**, will receive separate, sealed Bids for the project entitled, "**Roof Replacement – Middle School Auditorium**," at the Office of Warren County Financial Management Committee, C/O Warren County Finance Department, Warren County Administrative Office Building, 201 Locust Street, Suite 2, McMinnville, Tennessee 37110, until **2:00 P.M., CDT, Thursday, June 1, 2023** and then at said office, bids will be publicly opened.

**A Pre-Bid Meeting will be held on Tuesday, May 23, 2023 at 10:00 A.M., CDT at Warren County Middle School (ALL PARTIES SHALL CHECK IN AT OFFICE).**

The Instructions to Bidders, Form of Bid, Form of Contract, Plans, Specifications, Form of Bid Bond, Performance and Payment Bond and other Contract Documents may be examined at the following locations:

Richard C. Rinks & Associates, Inc., 30 North Jefferson, Cookeville, TN

All Contractors must be licensed under the provisions of the current Contractor's Licensing Act of Tennessee and shall be thoroughly familiar with all the provisions of said Act. All Bidders must comply with Tennessee Code Annotated, Title 62, in particular Chapter 6 regarding preparation of the Bid Envelope. Each Contractor shall submit his Bid in accordance with the requirements of the Licensing Act; in particular, giving his name, address, license number, license expiration date, the part of the classification of the license applying to the bid and the license dollar limitation, and shall mark the project bid for "Project Name," location of project, and the time, date and place of bid opening. Any Mechanical, Electrical, Plumbing or Roofing Contractor whose bid shall exceed \$25,000.00 is required by the Licensing Act to be licensed with the State Board for Licensing Contractors.

Copies of Plans and Specifications may be obtained at the office of the Designer, located in Cookeville, upon non-refundable payment of \$50.00 for each set. There is no fee for electronic copies of Plans and Specifications.

Warren County Schools reserves the right to waive any informality or to reject any or all bids. Each Bidder must deposit with his Bid Security in the amount of 5 percent of his Bid in the form and subject to the conditions provided in the Instructions to Bidders. 100% Performance and Payment Bonds will be required. No Bidder may withdraw his bid within 60 days after the actual date of the opening thereof.

The Warren County Financial Management Committee reserves the right to accept or reject any or all bids, to accept or reject any item thereon, to waive any irregularities in the bid or bidding and/or to abandon or postpone this project without any obligation to bidders. The Warren County Financial Management Committee will act as sole judge of the merit and qualifications of vendors and materials offered and accept whatever bid deemed to be in the best interest of Warren County. No bidder may withdraw their bid for a period of sixty (60) days after date set for opening of bids. The Financial Management Committee reserves the right to increase or decrease quantities.

Employees of the selected contractor must have a sexual predator background check performed prior to entering any Warren County school grounds as per Tennessee Code Annotated Section 49-5-413.

In case of tie bids, Warren County, Tennessee reserves the right to negotiate with bidders. By submission of this bid, the vendor agrees to all terms and condition stated therein.

No bids may be sent via e-mail or fax. Bidders shall enclose two (2) copies of the bid and note the bid submitted (i.e. **Roof Replacement – Middle School Auditorium**) on the outside of any shipping envelope if the bid envelope is contained inside.

Bids will be awarded accordingly as prescribed by law, which states "lowest and best." A Supreme Court ruling states that the discerning of best lies solely on those requesting the bid and not the bidder. No bidder may withdraw their bid for a period of sixty (60) days after date set of opening of the bids.

**PUBLIC NOTICE  
TITLE VI OF THE 1964 CIVIL RIGHTS ACT**

"No person in the United States shall, on the ground of race, color or national origin, be excluded from participation in, be denied the benefits of, or be subjected to discrimination under any program or activity receiving federal financial assistance."

Bids must be received by 2:00 P.M., CDT, Thursday, June 1, 2023 to be considered. Please return sealed bids to:

Warren County Financial Management Committee  
C/O Warren County Finance Department  
Warren County Administrative Office Building  
201 Locust Street, Suite 2  
McMinnville, Tennessee 37110

Pursuant to T.C.A. § 50-9-114, Warren County, Tennessee has adopted a Drug & Alcohol Testing Program and is required to include this information in our bid specifications. Warren County, Tennessee requires Alcohol and Controlled Substances testing for Safety-Sensitive Positions as required by the Federal Omnibus Transportation Employee Act of 1991 and related United States Department of Transportation rules and regulations set forth in 49 CFR Federal Regulations Parts 40 and 382. **BIDDERS MUST SUBMIT AN AFFIDAVIT THAT THE BIDDER OPERATES A DRUG AND ALCOHOL TESTING PROGRAM WITH REQUIREMENTS AT LEAST AS STRINGENT AS THAT OF THE PROGRAM OPERATED BY WARREN COUNTY, TENNESSEE.**

**This institution is an equal opportunity provider and employer**

If you wish to file a Civil rights program complaint of discrimination, complete the USDA Program Discrimination Complaint Form, found online at [http://www.ascr.usda.gov/complaint\\_filing\\_file.html](http://www.ascr.usda.gov/complaint_filing_file.html), or at any USDA office, or call (868) 632-9992 to request the form. You may also write a letter containing all the information requested in the form. Send your completed complaint form or letter to us by mail at E. S. Department of Agriculture, Washington D.C. 20250-9410, by fax (202) 690-7442 or email at [program.intake@usda.gov](mailto:program.intake@usda.gov).

**PROJECT MANUAL**

**ROOF REPLACEMENT**  
**MIDDLE SCHOOL AUDITORIUM**  
**MCMINNVILLE, TENNESSEE**  
**FOR**  
**WARREN COUNTY SCHOOLS**

**MAY 1, 2023**

**RICHARD C. RINKS & ASSOCIATES, INC.**  
**ENGINEERING AND ARCHITECTURAL SERVICES**  
**BUILDING ENCLOSURE CONSULTANTS**  
**30 NORTH JEFFERSON AVENUE 38501**  
**COOKEVILLE, TENNESSEE**  
**PHONE: 931-528-5543**  
**FAX: 931-528-5544**  
**Rinks-Consulting.com**

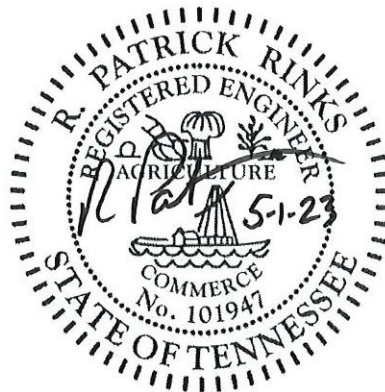

**PROJECT NO. 2971**

**SET NO. \_\_\_\_\_**

## TABLE OF CONTENTS

DESCRIPTION	SECTION	PAGES	SUBMITTALS	
NOTICE TO BIDDERS .....		2		
INSTRUCTIONS TO BIDDERS .....	00100	4		
*5% BOND .....	00104	2		
*BID FOR LUMP SUM CONTRACTS .....	00300	4		
*DRUG-FREE WORKPLACE AFFIDAVIT .....	00802	1		
*CRIMINAL BACKGROUND COMPLIANCE AFFIDAVIT .....	00803	1		
PERSONNEL USED IN CONTRACT PERFORMANCE ATTESTATION .....	00804	1		
*CERTIFICATION OF COMPLIANCE WITH THE IRAN DIVESTMENT ACT .....	00805	2		
*NON-BOYCOTT OF ISRAEL CERTIFICATION.....	00806	1		
CERTIFICATE OF SUBSTANTIAL COMPLETION ...	00807	2		
CONTRACTOR REQUEST FOR INSPECTION .....	00808	1		
FORM OF GUARANTEE .....	00810	1		
WAIVER AND RELEASE OF LIEN .....	00811	1		
STANDARD FORM OF AGREEMENT BETWEEN OWNER AND CONTRACTOR .....		4		
PERFORMANCE BOND AND LABOR AND MATERIAL PAYMENT BOND .....		4		
GENERAL CONDITIONS OF THE CONTRACT FOR CONSTRUCTION (A201) .....		19		
SUPPLEMENTARY GENERAL CONDITIONS .....	00850	5		
GENERAL REQUIREMENTS .....	01000	5		C
SUMMARY OF WORK .....	01010	2		
WEATHER DELAYS .....	01252	2		
CLEANING .....	01710	1		
METAL DECK .....	05100	1	SD	ML
ROUGH CARPENTRY .....	06100	3	SD	ML
INSULATION ATTACHMENT .....	07205	2		ML S
ROOF INSULATION .....	07210	2	SD	ML
MEMBRANE ROOFING AND ACCESSORIES .....	07500	6	SD	ML
FLASHING AND SHEET METAL .....	07600	3	SD	ML
CAULKING .....	07900	2		ML
PAINTING .....	09900	4		S O

Divisions are the first two digits of the section number.  
 Submittals shown here are for quick reference and are the same as those shown at the top of the first page of each technical section.

**\*SECTION TO BE SUBMITTED WITH BID**

A. Instructions obtained in the Legal Notice to Bidders, Instructions to Bidder, Bulletins, General Conditions, Supplementary General Conditions, Modifications to General Conditions, Special Conditions, Addenda, all Sections of the Specifications, and all Drawings shall become part of this Contract. All references herein to "Architect" or "Engineer" shall include "Designer" and "Roof Consultant."

B. Preparation of Bids:

Signatures must be in longhand and executed by principal duly authorized to enter into Contracts. The Bidder's legal name must be fully stated. The complete form shall be without authorization or erasure. Oral telephone Proposals for modifications will not be considered.

C. Definitions:

1. Owner: **Warren County Schools**
2. Contractor: The party or parties contracting to perform the work to be done under this Contract or legal representatives of such party or parties.
3. Roof Consultant: Richard C. Rinks & Associates, Inc., 30 North Jefferson Avenue (38501), Post Office Box 691 (38503), Cookeville, Tennessee

D. Qualifications of Bidders:

In selecting the General Contractor, time required for the construction being paramount, type of work completed, experience and financial status of Bidders and their proposed Subcontractors will be considered, as well as the Proposal submitted.

E. Compliance with Licensing Law:

Contractors shall be thoroughly familiar with the current Contractor's Licensing Act and comply with all Sections contained therein. Contractor shall be properly licensed at the time of Bid and provide evidence of compliance with the applicable provisions of Tennessee Code Annotated (TCA) Chapter 62-6-119 before Bid may be considered.

## F. Bulletins and Addenda:

Should a Bidder find discrepancies, ambiguities, or omissions in the Drawings or Specifications, or should he be in doubt as to the meaning, he will at once notify the Engineer, who will send a written bulletin to all Bidders. The Engineer will not be responsible for any oral instructions. All bulletins to Bidders shall be incorporated in the Bidder's Proposal and will become a part of the Contract Documents.

## G. Contractors must be thoroughly familiar with the current Contractor's Licensing Act and comply with all Sections contained therein.

## H. Each Bidder shall submit with his Proposal a list of proposed Subcontractors for the project, including license number if required.

## I. Liquidated Damages for Failure to Enter into Contract:

The successful Bidder, upon his failure or refusal to execute and deliver the Contract and Bonds required within ten (10) days after he has received notice of the acceptance of his Bid, shall forfeit to the Owner, as Liquidated Damages for such failure or refusal, the security deposited with his Bid.

## J. Time of Completion of Liquidated Damages:

Bidder must agree to commence work on or before a date to be specified in a written "Notice to Proceed" of the Owner and to fully complete the Project **within Sixty (60) consecutive calendar days after date of Notice to Proceed**. Bidder must agree also to pay as liquidated damages the sum of **two hundred dollars (\$200.00)** for each consecutive calendar day thereafter as hereinafter provided in the General Conditions.

K. Conditions of Work:

Each Bidder must inform himself fully of the conditions relating to the construction of the project and the employment of labor thereon. Failure to do so will not relieve a successful Bidder of his obligation to furnish all material and labor necessary to carry out the provisions of his Contract. Insofar as possible, the Contractor, in carrying out his work, must employ such methods or means as will not cause any interruption of or interference with the work of any other Contractor.

Failure of any Bidder to receive any Addendum mailed by the Engineer, or interpretations, or bulletins, shall not relieve such Bidder of any obligation under his Bid as submitted. All Addenda and such bulletins issued become a part of the Contract Documents. Each Bidder, once awarded the Contract, will be expected to furnish Performance and Labor and Materials Payment Bonds in the amount of 100 percent of the Contract, executed by a duly authorized surety company satisfactory to the Owner.

L. Obligations of the Bidder:

At the time of opening of Bids, each Bidder will be presumed to have inspected the Site and to have read and be thoroughly familiar with the Plans and Contract Documents (including all Addenda). The failure or omission of any Bidder to examine any form, instrument or document shall in no way relieve any Bidder from any obligation in respect of his Bid.

Any questions from Bidders concerning this project, either before or after the Bid date, shall be directed to the following:

Jason Rinks, Richard C. Rinks & Associates, Inc., 30 North Jefferson Avenue, Cookeville, Tennessee 38501. Telephone No. 931-528-5543

M. Contractor must submit his Bid in a sealed envelope at the designated place of Bid opening prior to the time of opening.

The envelope must contain on the outside of the envelope the following data:

1. Contractor's Name
2. Contractor's Address

3. Contractor's License Number
4. Contractor's License Expiration Date
5. Contractor's License Classification Applying to the Bid
6. Contractor's License Dollar Limitation
7. Marked Bid for "Project Name"
8. Location of Project
9. Date, Time and Place of Bid Opening
10. Bidder must list on the outside of the Bid Envelope Mechanical, Plumbing, Electrical and Roofing Subcontractors which will be used on this project per Tennessee License and Bidding requirements. The same appropriate information listed for the prime Contractor must also be listed for the Subcontractors.

Failure to comply with all ten of the above requirements will result in the rejection of the Bid and return of same unopened.

11. Contractor shall submit sealed Bid Envelope which will include price and other required documentation. Correct information shall be listed on the outside of the Envelope and all required Documentation shall be included inside Bid Envelope.

END OF SECTION



KNOW ALL MEN BY THESE PRESENTS, that we, the undersigned,  
 \_\_\_\_\_, as Principal, and  
 \_\_\_\_\_, as Surety, are hereby held and  
 firmly bound unto **Warren County Schools** as Owner, in the penal sum of  
 \_\_\_\_\_ for the payment of which,  
 well and truly to be made, we hereby jointly and severally bind ourselves, our  
 heirs, executors, administrators, successors and assigns.

Signed, this \_\_\_\_ day of \_\_\_\_\_, 2023.

The condition of the above obligation is such that whereas the Principal has  
 submitted to **Warren County Schools** a certain bid, attached hereto and hereby  
 made a part hereof, to enter into a Contract in writing, for  
 the "**Roof Replacement – Middle School Auditorium**".

NOW, THEREFORE,

- (a) If said Bid shall be rejected, or in any alternate,
- (b) If said Bid shall be accepted and the Principal shall execute and deliver a Contract in the form of Contract attached hereto (properly completed in accordance with said Bid) and shall furnish a Bond for his faithful performance of said Contract, and for the payment of all persons performing labor or furnishing materials in connection therewith, and shall in all other respects perform the agreement created by the acceptance of said Bid, then this obligation shall be void; otherwise, the same shall remain in force and effect, it being expressly understood and agreed that the liability of the Surety for any and all claims hereunder shall, in no event, exceed the penal amount of this obligation as herein stated.

The Surety, for value received, hereby stipulates and agrees that the obligations of said Surety and its Bond shall in no way be impaired or affected by any extension of the time within which the Owner accepts such Bid, and said Surety does hereby waive notice of any such extension.

IN WITNESS WHEREOF, the Principal and the Surety have hereunto set their hands and seals, and such of them as are corporations have caused their corporate seals to be hereto affixed and these presents to be signed by their proper officers, the day and year first set forth above.

\_\_\_\_\_  
Principal

\_\_\_\_\_  
By

\_\_\_\_\_  
Surety

\_\_\_\_\_  
By

END OF SECTION

Place: **Warren County Administrative Office Building**

Date: **June 1, 2023**

Project No.: **2971**

Proposal of \_\_\_\_\_

(hereinafter called "Bidder") a \_\_\_\_\_  
(State)

Corporation/a partnership/an individual \_\_\_\_\_  
(STRIKE OUT INAPPLICABLE TERMS)

(doing business as \_\_\_\_\_).

To **Warren County Schools**: (hereinafter called "Owner")

Gentlemen:

The Bidder, in compliance with your invitation for Bids for the project titled "**Roof Replacement – Middle School Auditorium**," having examined the Plans and Specifications with related documents and the site of the proposed work, and being familiar with all conditions surrounding the construction of the proposed project, including the availability of materials and labor, hereby proposes to furnish all labor, materials, and supplies, and to construct the project in accordance with the Contract Documents within the time set forth therein and at the prices stated below. These prices are to cover all expenses incurred in performing the work required under the Contract Documents, of which this proposal is a part.

Bidder must agree to commence work on or before a date to be specified in a written "Notice to Proceed" of the Owner and to fully complete the Project **within Sixty (60) consecutive calendar days after date of Notice to Proceed**. Bidder must agree also to pay as liquidated damages the sum of **two hundred dollars (\$200.00)** for each consecutive calendar day thereafter as hereinafter provided in the General Conditions.

Bidder acknowledges receipt of the following addendum:

\_\_\_\_\_

**BASE BID (60 Consecutive Calendar Days):** Remove and properly dispose of all debris, adhered EPDM roof membrane, tapered EPS insulation and flashings to existing isocyanurate insulation. Back out and remove all insulation fasteners and plates. Inspect existing isocyanurate insulation with Delmhorst meter and replace all wet and/or damaged insulation. Remove and properly dispose of edge metal, metal coping, gutters, downspouts, conductor heads, metal fascia cover, faceplates and metal counterflashing at locations shown on the Plans. Provide and install new wood blocking at locations shown on the Plans. Treat any rusted metal deck with rust inhibitor and replace any metal and/or wood deck which will not achieve proper pull results. Remove and reinstall/replace existing insulation around perimeter and penetrations as required to install new EPDM air barrier and high-density foam. Mechanically attach new 1.5" isocyanurate, 1/8" per foot tapered isocyanurate and 1/4" per foot isocyanurate crickets using fastener pattern shown on the Plans. In foam adhesive, provide and install new 1/2" cover board to new isocyanurate insulation using foam pattern shown on the Plans. Provide and install new .060", FR, non-reinforced, black, fully adhered EPDM Roof System with a 20-Year, No Dollar Limit, Warranty with 72 mph wind speed and 2" diameter Hail Warranty. Provide and install new Kynar 500 edge metal, metal coping, gutters, downspouts, fascia cover, conductor heads and metal counterflashing. Provide and install new overflow scuppers and faceplates at location shown on the Plans. All metal work shall meet ES-1 attachment requirements. Contractor shall include in Base Bid a \$20,000.00 Allowance for unforeseen conditions.

---

(\$ \_\_\_\_\_ )

---

Written Amount

\*\*\*\*\*  
 \*\*\*\*\*

**ADD ALTERNATE 1:** Provide and install a fully adhered, LSFR, non-reinforced, black, .090" EPDM membrane in lieu of .060" EPDM membrane. Provide 30-Year, NDW Warranty with 72 mph wind speed, Accidental Puncture and 2" hail Warranty.

---

(\$ \_\_\_\_\_ )

---

Written Amount

**EPDM MANUFACTURER:** \_\_\_\_\_

**UNIT PRICES:**

Contractor to provide unit prices for the following items. This price shall include all labor, materials, taxes, overhead and profit and all other miscellaneous costs required to remove and replace these items.

- New 1.5" matching metal deck      \$ \_\_\_\_\_ per square foot
- New 3/4" plywood                      \$ \_\_\_\_\_ per square foot
- New rust inhibitor                    \$ \_\_\_\_\_ per square foot
- New wood blocking                  \$ \_\_\_\_\_ per board foot
- New 1.5" replacement isocyanurate \$ \_\_\_\_\_ per square foot

The Owner may award the Bid to the Bidder demonstrating the most complete response and full compliance with the Specifications of each item.

The Owner reserves the right to offer an Award on any combination of factors it determinates to be in the interests of the County and County's residents. Price may be a factor, but may not be the sole factor affecting the Awarding of the Bid. The Bid will be awarded to the "best Bidder" and not the "low Bidder". The Owner will make the determination of which Bidder is the "best Bidder" and not the Bidder.

The Owner reserves the right to negotiate with the successful Bidder on Alternates or changes to the Bid.

Bidder understands that the Owner reserves the right to reject any or all Bids and to waive any informalities in the Bidding.

The Bidder agrees that this Bid shall be good and may not be withdrawn for a period of sixty (60) calendar days after the scheduled closing time for receiving Bids.

Upon receipt of written notice of the acceptance of this Bid, Bidder will execute the formal Contract attached within ten (10) days and deliver as required by the General Conditions.

The Bid security attached, in the sum of \_\_\_\_\_

\_\_\_\_\_  
(\$ \_\_\_\_\_), is to become the property of the Owner in the event the Contract and Bond are not executed within the time above set forth as liquidated damages for the delay and additional expense to the Owner caused thereby.

Respectfully submitted,

BY: \_\_\_\_\_  
(Signature)

\_\_\_\_\_  
(Title)

\_\_\_\_\_  
(Business Address)

END OF SECTION

DRUG-FREE WORKPLACE AFFIDAVIT

STATE OF \_\_\_\_\_

COUNTY OF \_\_\_\_\_

The undersigned, principal officer of \_\_\_\_\_ an employer of five (5) or more employees contracting with **Warren County Schools** to provide construction services, hereby states under oath as follows:

- I. The under signed is a principal officer of \_\_\_\_\_ (hereinafter referred to as the "Company"), and is duly authorized to execute this Affidavit on behalf of the Company.
- 2. The Company submits this Affidavit pursuant to T.C.A. § 50-9-113, which requires each employer with no less than five (5) employees receiving pay who contracts with the state or any local government to provide construction services to submit an affidavit stating that such employer has a drug-free workplace program that complies with Title 50, Chapter 9, of the *Tennessee Code Annotated*
- 3. The Company is in compliance with T.C.A. § 50-9-114.

Further affiant saith not.

\_\_\_\_\_  
**Principal Officer**

STATE OF \_\_\_\_\_

COUNTY OF \_\_\_\_\_

Before me personally appeared \_\_\_\_\_, with whom I am personally acquainted (or proved to me on the basis of satisfactory evidence), and who acknowledged that such person executed the forgoing affidavit for the purposes therein contained.

Witness my hand and seal at office this \_\_\_\_\_ day of \_\_\_\_\_ 2023.

\_\_\_\_\_  
Notary Public

My commission expires: \_\_\_\_\_

**CRIMINAL BACKGROUND COMPLIANCE AFFIDAVIT**

**STATE OF** \_\_\_\_\_

**COUNTY OF** \_\_\_\_\_

The undersigned, principal officer of \_\_\_\_\_, an employer contracting with Warren County Schools to provide services having direct contact with children or access to grounds of a Warren County Public School, hereby states under oath as *follows*:

1. The undersigned is a principal officer of \_\_\_\_\_ (hereinafter referred to as the "Company"), and is duly authorized to execute this Affidavit on behalf of the Company.
2. The Company submits this Affidavit pursuant to T.C.A. § 49-5-413 as amended effective September 1, 2007 for entities entering into contracts with a local board of education where the company's employees will have direct contact with school children or access to the grounds of a school when children are present. It is the duty of the Company to require applicants supply a fingerprint sample and submit to a criminal history records check to be conducted by the Tennessee Bureau of Investigation and the Federal Bureau of Investigation prior to permitting the person to have contact with such children or enter school grounds and to take certain other actions based upon the results of the records check.
3. The Company is in compliance with the terms of T.C.A. § 49-5-413.

Further affiant saith naught.

\_\_\_\_\_

**Principal Officer**

**STATE OF** \_\_\_\_\_

**COUNTY OF** \_\_\_\_\_

Before me personally appeared \_\_\_\_\_ with whom I am personally acquainted (or proved to me on the basis of satisfactory evidence), and who acknowledged that he/she is the \_\_\_\_\_ of \_\_\_\_\_ and is authorized to execute this instrument on behalf of the principal for the purposes therein contained.

Witness my hand and seal at office this \_\_\_\_\_ day of \_\_\_\_\_, 2023.

\_\_\_\_\_

**My commission expires:** \_\_\_\_\_

**END OF SECTION**



This form shall be completed and attached with first Pay Request only.

Project Title	Roof Replacement Middle School Auditorium McMinnville, Tennessee
Legal Entity Name of the Party Participating in the Contract	
Federal Employer Identification Number (or Social Security Number)	

The Party, identified above, does hereby attest, certify, warrant and assure that the Party shall not knowingly utilize the services of an illegal immigrant in the performance of this Contract and shall not knowingly utilize the services of any subcontractor or consultant who will utilize the services of an illegal immigrant in the performance of this Contract.

Signature: \_\_\_\_\_

Date: \_\_\_\_\_

Name: \_\_\_\_\_

Title: \_\_\_\_\_

Notice: An individual empowered to contractually bind the Party must sign this attestation. If said individual is not the chief executive or president, this document shall be attached to evidence showing the individual's authority to contractually bind the Party.

END OF SECTION

Effective July 1, 2016, this form must be submitted for any contract that is subject to the Iran Divestment Act, Tenn. Code Ann. § 12-12-101, et seq., (“Act”). This form must be submitted with any bid or proposal regardless of where the principal place of business is located.

Pursuant to the Act, this certification must be completed by any corporation, general partnership, limited partnership, limited liability partnership, joint venture, nonprofit organization, or other business Organization that is contracting with a political subdivision of the State of Tennessee.

**Certification Requirements.**

No state agency or local government shall enter into any contract subject to the Act, or amend or renew any such contract with any bidder/contractor who is found ineligible under the Act.

Complete all sections of this certification and sign and date it, under oath, in the presence of a Notary Public or a person authorized to take an oath in another state.

**CERTIFICATION:**

I, the undersigned, certify that by submission of this bid, each bidder and each person signing on behalf of any Respondent certifies, and in the case of a joint bid or contract each party thereto certifies, as to its own organization, under penalty of perjury, that to the best of its knowledge and belief that each bidder is not on the list created pursuant to Tenn. Code Ann. § 12-12-106.

Respondent represents it has the full power, knowledge, and authority to make this Certification and that the signatory signing this Certification on behalf of bidder/contractor has been duly authorized to do so on behalf of the bidder/contractor.

Sworn as true to the best of my knowledge and belief, subject to the penalties of false statement.

\_\_\_\_\_  
Printed Respondent Name Printed Name of Authorized Official

\_\_\_\_\_  
Signature of Authorized Official

\_\_\_\_\_  
Date

STATE OF \_\_\_\_\_

COUNTY OF \_\_\_\_\_

Before me personally appeared \_\_\_\_\_, with whom I am personally acquainted (or proved to me on the basis of satisfactory evidence), and who acknowledged that such person executed the forgoing affidavit for the purposes therein contained.

Witness my hand and seal at office this \_\_\_\_\_ day of \_\_\_\_\_ 20\_\_\_\_.

\_\_\_\_\_  
Notary Public

My commission expires: \_\_\_\_\_

END OF SECTION

Tenn. Code Ann. § 12-4-119 prohibits public entities from entering into a contract for services, supplies, information technology or construction unless the contract includes a written certification that the company is not currently engaged in, and will not be engaged in for the duration of the contract, a boycott of Israel. This applies to any contract entered into on or after July 1, 2022. The law does not apply to contracts with a value of less than \$250,000 or in contracts where the supplier has less than ten employees.

A boycott of Israel means engaging in refusals to deal, terminating business activities or other commercial actions that are intended to limit commercial relations with Israel, or companies doing business in or with Israel or authorized by, licensed by or organized under the laws of the State of Israel to do business, or persons or entities doing business in Israel, when such actions are taken: (1) In compliance with, or adherence to, calls for a boycott of Israel, or (2) In a manner that discriminates on the basis of nationality, national origin, religion, or other unreasonable basis and is not based on a valid business reason. Tenn. Code Ann. § 12-4-119.

**Certification Requirements.**

Complete all sections of this certification and sign and date it, under oath, in the presence of a Notary Public or a person authorized to take an oath in another state.

**CERTIFICATION:**

The Contractor certifies that it is not currently engaged in, and will not for the duration of the contract engage in, a boycott of Israel as defined by Tenn. Code Ann. § 12-4-119. This provision shall not apply to contracts with a total value of less than two hundred fifty thousand dollars (\$250,000) or to contractors with less than ten (10) employees.

\_\_\_\_\_  
Printed Name and Title of Authorized Official

\_\_\_\_\_  
Signature of Authorized Official

\_\_\_\_\_  
Date

**STATE OF** \_\_\_\_\_

**COUNTY OF** \_\_\_\_\_

Before me personally appeared \_\_\_\_\_, with whom I am personally acquainted (or proved to me on the basis of satisfactory evidence), and who acknowledged that such person executed the foregoing affidavit for the purposes therein contained.

Witness my hand and seal at office this \_\_\_\_\_ day of \_\_\_\_\_ 20\_\_\_\_\_.

\_\_\_\_\_  
Notary Public

My commission expires: \_\_\_\_\_

END OF SECTION

Date: \_\_\_\_\_

Project: **"Roof Replacement – Middle School Auditorium "**

Owner: **Warren County Schools**

The work performed under subject Contract has been reviewed and been found to be substantially completed with the exception of the attached list of items to be corrected and/or completed by the Contractor, referred to as the "Punch List." This list may not be exhaustive or complete, and failure to include an item on it does not alter the responsibility of the Contractor to complete all the work in accordance with the Contract Documents, including all Change Orders thereto.

The Contractor will complete and/or correct the work on the Punch List attached on or before \_\_\_\_\_. The Owner accepts the project or specified area of the project as substantially complete and assumes full responsibility therefore as of \_\_\_\_\_ at \_\_\_\_\_.

The responsibility of insurance shall be as follows:

1. Workman's Compensation and Contractor's Public Liability shall be carried by the Contractor until such time as the attached Punch List of incomplete and/or incorrect work is completed, corrected and accepted by the Owner.
2. Fire with extended coverage, vandalism, and malicious mischief completed value form shall be carried by the Owner.
3. In addition, at his option, the Owner may maintain his own public liability insurance.

Acceptance recommended by: Richard C. Rinks & Associates, Inc., Cookeville, Tennessee

By: \_\_\_\_\_ Date: \_\_\_\_\_

Contractor agrees to complete and/or correct the work on the Punch List on or before \_\_\_\_\_.

\_\_\_\_\_

Contractor

By: \_\_\_\_\_ Date: \_\_\_\_\_

Project accepted as substantially complete by:

\_\_\_\_\_

**Warren County Schools**

By: \_\_\_\_\_ Date: \_\_\_\_\_

END OF SECTION

---

ROOFING CONTRACTOR LETTERHEAD

Mr. Jason Rinks  
Richard C. Rinks & Associates, Inc.  
30 North Jefferson Avenue  
Cookeville, Tennessee 38501  
jason@rinks-consulting.com

via email

Re: **"Roof Replacement – Middle School Auditorium"**

Dear Mr. Rinks:

Our firm is substantially complete with the above captioned Project. This letter is to request your inspection of the Project as soon as possible.

In preparation for your inspection, our supervisory staff has conducted a Complete Punch List Inspection of the roof, and all noted deficiencies have been properly repaired. This Punch List Inspection conducted by our staff consisted of our staff's inspection of the entire field of the roof, probing all field seams, pourable sealer pans, flashing, seams and strip-in, and inspecting all metal work on the Project. Our Punch List Inspection has been conducted since all work was completed and is not merely a collection of inspections performed as the Project progressed. A copy of our Punch List Inspection is enclosed.

By requesting this inspection, we hereby certify that the Project is complete and ready for your inspection. Should your inspection reveal excessive deficiencies, we understand you will terminate the inspection and have to schedule another inspection at a later date at our costs.

Respectfully submitted,

\_\_\_\_\_ DATE: \_\_\_\_\_

Enclosure: Contractor's Punch List Inspection  
Manufacturer's Punch List Inspection

**NOTICE: RCR&A WILL NOT CONDUCT THE INSPECTION WITHOUT CONTRACTOR'S AND MANUFACTURER'S PUNCH LIST BEING ATTACHED TO THIS REQUEST FOR INSPECTION !**

END OF SECTION

Pursuant to these Specifications, we, the undersigned Contractor for the Roofing and Sheet Metal Work on the Project entitled, "**Roof Replacement – Middle School Auditorium,**" hereby guarantees all workmanship, materials, and other items covered by our Contract for a period of two (2) years from the date of Substantial Completion as evidenced by the date below:

\_\_\_\_\_  
Roofing & Sheet Metal Contractor

Date: \_\_\_\_\_

By: \_\_\_\_\_

BASE BID: Roofing Material Manufacturer's Roof Warranty shall be a 20-Year, No Dollar Limit Warranty with 72 mph wind speed and 2" diameter hail warranty.

ADD ALTERNATE 1: Roofing Material Manufacturer's Roof Warranty shall be a 30-Year, No Dollar Limit Warranty with 72 mph wind speed, accidental puncture warranty and 2" diameter hail warranty. 30-year puncture warranty shall include 32 man hours per year.

ALL MANUFACTURER'S WARRANTIES SHALL INCLUDE A STATEMENT OR A SUPPLEMENTAL LETTER STATING THAT: WHEN REPAIRING LEAKS, ALL WET INSULATION SHALL BE CUT OUT AND REPLACED UNDER THE TERMS AND CONDITIONS OF THE WARRANTY. CONTRACTOR SHALL NOT JUST PATCH THE ROOF MEMBRANE.

THE CONTRACTOR SHALL SUBMIT THE TOTAL SYSTEM ROOF WARRANTY MEMORANDUM OF UNDERSTANDING TO THE MANUFACTURER PRIOR TO BID AND WITH THE ORDER FOR MATERIALS SUBMISSION. THE CONTRACTOR AND ROOF SYSTEM MANUFACTURER SHALL SIGN THE TOTAL SYSTEM ROOF WARRANTY MEMORANDUM OF UNDERSTANDING. UPON COMPLETION OF THE PROJECT, PROVIDE THE SIGNED COPY OF THE TOTAL SYSTEM ROOF WARRANTY MEMORANDUM OF UNDERSTANDING ALONG WITH THE TOTAL SYSTEM WARRANTY.

END OF SECTION



Whereas, the undersigned \_\_\_\_\_  
(Name of Manufacturer, Materialman or Subcontractor)

has furnished to \_\_\_\_\_  
(Name of Contractor)

the following \_\_\_\_\_  
(Kind of Material and Services Furnished)

for use in construction of a Project belonging to **Warren County Schools.**

Now, therefore, the undersigned \_\_\_\_\_  
(Manufacturer, Materialman or Subcontractor)

and in consideration of \$ \_\_\_\_\_, and other goods and valuable consideration, the receipt whereof is hereby acknowledged, do(es) hereby waive and release any and all liens, or right to or claim of lien, on the above described project and premises, under any law, common or statutory, on account or labor or materials, or both, heretofore or hereafter furnished by the undersigned to or for the account

of said \_\_\_\_\_  
(Name of Contractor)

for said project.

Given under my (our) hand(s) and seal(s) this \_\_\_\_\_

day of \_\_\_\_\_, 202\_\_.

\_\_\_\_\_  
(Name of Manufacturer, Materialman, or Subcontractor)

By: \_\_\_\_\_  
(Title)

END OF SECTION

# THE AMERICAN INSTITUTE OF ARCHITECTS



AIA Document A101

## Standard Form of Agreement Between Owner and Contractor

where the basis of payment is a

STIPULATED SUM

1977 EDITION

*THIS DOCUMENT HAS IMPORTANT LEGAL CONSEQUENCES; CONSULTATION WITH  
AN ATTORNEY IS ENCOURAGED WITH RESPECT TO ITS COMPLETION OR MODIFICATION*

*Use only with the 1976 Edition of AIA Document A201, General Conditions of the Contract for Construction.*

This document has been approved and endorsed by The Associated General Contractors of America.

### AGREEMENT

made as of the \_\_\_\_\_ day of \_\_\_\_\_ in the year of \_\_\_\_\_

BETWEEN the Owner: WARREN COUNTY SCHOOLS  
2548 Morrison Street  
McMinnville, Tennessee 37110

and the Contractor:

The Project: Roof Replacement - Middle School Auditorium  
McMinnville, Tennessee

The Architect: RICHARD C. RINKS & ASSOCIATES, INC.  
30 North Jefferson Avenue  
Cookeville, Tennessee 38501

The Owner and the Contractor agree as set forth below.

Copyright 1915, 1918, 1925, 1937, 1951, 1958, 1961, 1963, 1967, 1974, © 1977 by the American Institute of Architects, 1735 New York Avenue, N.W., Washington, D. C. 20006. Reproduction of the material herein or substantial quotation of its provisions without permission of the AIA violates the copyright laws of the United States and will be subject to legal prosecution.

ARTICLE 1

**THE CONTRACT DOCUMENTS**

The Contract Documents consist of this Agreement, the Conditions of the Contract (General, Supplementary and other Conditions), the Drawings, the Specifications, all Addenda issued prior to and all Modifications issued after execution of this Agreement. These form the Contract, and all are as fully a part of the Contract as if attached to this Agreement or repeated herein. An enumeration of the Contract Documents appears in Article 7.

ARTICLE 2

**THE WORK**

The Contractor shall perform all the Work required by the Contract Documents for  
*(Here insert the caption descriptive of the Work as used on other Contract Documents.)*

Roof Replacement - Middle School Auditorium  
McMinnville, Tennessee

ARTICLE 3

**TIME OF COMMENCEMENT AND SUBSTANTIAL COMPLETION**

The Work to be performed under this Contract shall be commenced

and, subject to authorized adjustments, Substantial Completion shall be achieved not later than

*(Here insert any special provisions for liquidated damages relating to failure to complete on time.)*

Sixty (60) consecutive calendar days after date of Notice  
to Proceed with Liquidated Damages of Two Hundred Dollars  
(\$200.00) per day for each consecutive calendar day thereafter.

ARTICLE 4  
**CONTRACT SUM**

The Owner shall pay the Contractor in current funds for the performance of the Work, subject to additions and deductions by Change Order as provided in the Contract Documents, the Contract Sum of

The Contract Sum is determined as follows:  
*(State here the base bid or other lump sum amount, accepted-alternates, and unit prices, as applicable.)*

ARTICLE 5  
**PROGRESS PAYMENTS**

Based upon Applications for Payment submitted to the Architect by the Contractor and Certificates for Payment issued by the Architect, the Owner shall make progress payments on account of the Contract Sum to the Contractor as provided in the Contract Documents for the period ending the last day of the month as follows:

Not later than sixty (60) days following the end of the period covered by the Application for Payment ninety-five percent ( 95% ) of the portion of the Contract Sum properly allocable to labor, materials and equipment incorporated in the Work and ninety-five percent ( 95% ) of the portion of the Contract Sum properly allocable to materials and equipment suitably stored at the site or at some other location agreed upon in writing, for the period covered by the Application for Payment, less the aggregate of previous payments made by the Owner; and upon Substantial Completion of the entire Work, a sum sufficient to increase the total payments to one hundred percent ( 100% ) of the Contract Sum, less such amounts as the Architect shall determine for all incomplete Work and unsettled claims as provided in the Contract Documents.

*(If not covered elsewhere in the Contract Documents, here insert any provision for limiting or reducing the amount retained after the Work reaches a certain stage of completion.)*

Payments due and unpaid under the Contract Documents shall bear interest from the date payment is due at the rate entered below, or in the absence thereof, at the legal rate prevailing at the place of the Project.  
*(Here insert any rate of interest agreed upon.)*

*(Usury laws and requirements under the Federal Truth in Lending Act, similar state and local consumer credit laws and other regulations at the Owner's and Contractor's principal places of business, the location of the Project and elsewhere may affect the validity of this provision. Specific legal advice should be obtained with respect to deletion, modification, or other requirements such as written disclosures or waivers.)*

ARTICLE 6

**FINAL PAYMENT**

Final payment, constituting the entire unpaid balance of the Contract Sum, shall be paid by the Owner to the Contractor when the Work has been completed, the Contract fully performed, and a final Certificate for Payment has been issued by the Architect.

ARTICLE 7

**MISCELLANEOUS PROVISIONS**

7.1 Terms used in this Agreement which are defined in the Conditions of the Contract shall have the meanings designated in those Conditions.

7.2 The Contract Documents, which constitute the entire agreement between the Owner and the Contractor, are listed in Article 1 and, except for Modifications issued after execution of this Agreement, are enumerated as follows:

*(List below the Agreement, the Conditions of the Contract (General, Supplementary, and other Conditions), the Drawings, the Specifications, and any Addenda and accepted alternates, showing page or sheet numbers in all cases and dates where applicable.)*

Standard Form of Agreement Between Owner and Contractor.

Project Manual dated May 1, 2023, for Roof Replacement - Middle School Auditorium for Warren County Schools, prepared by Richard C. Rinks & Associates, Inc.

Project Drawings dated May 1, 2023, for Roof Replacement - Middle School Auditorium for Warren County Schools, prepared by Richard C. Rinks & Associates, Inc., consisting of the following sheets:

- T1 - Title Sheet
- G1 - Notes
- R1 - Demolition Roof Plan
- R2 - New Roof Plan
- D1 - New Roof Details
- D2 - New Roof Details
- D3 - New Roof Details
- D4 - New Roof Details

This Agreement entered into as of the day and year first written above.

OWNER

CONTRACTOR

WARREN COUNTY SCHOOLS

\_\_\_\_\_  
\_\_\_\_\_  
\_\_\_\_\_

\_\_\_\_\_  
\_\_\_\_\_  
\_\_\_\_\_

# THE AMERICAN INSTITUTE OF ARCHITECTS



AIA Document A311

## Performance Bond

KNOW ALL MEN BY THESE PRESENTS: that

(Here insert full name and address or legal title of Contractor)

as Principal, hereinafter called Contractor, and,

(Here insert full name and address or legal title of Surety)

as Surety, hereinafter called Surety, are held and firmly bound unto

(Here insert full name and address or legal title of Owner)

as Oblige, hereinafter called Owner, in the amount of

Dollars (\$ \_\_\_\_\_),

for the payment whereof Contractor and Surety bind themselves, their heirs, executors, administrators, successors and assigns, jointly and severally, firmly by these presents.

WHEREAS,

Contractor has by written agreement dated \_\_\_\_\_

(Here insert full name, address and description of project)

20 \_\_\_\_\_, entered into a contract with Owner for

in accordance with Drawings and Specifications prepared by

(Here insert full name and address or legal title of Architect)

which contract is by reference made a part hereof, and is hereinafter referred to as the Contract.

# PERFORMANCE BOND

NOW, THEREFORE, THE CONDITION OF THIS OBLIGATION is such that, if Contractor shall promptly and faithfully perform said Contract, then this obligation shall be null and void; otherwise it shall remain in full force and effect.

The Surety hereby waives notice of any alteration or extension of time made by the Owner.

Whenever Contractor shall be, and declared by Owner to be in default under the Contract, the Owner having performed Owner's obligations thereunder, the Surety may promptly remedy the default, or shall promptly

1) Complete the Contract in accordance with its terms and conditions, or

2) Obtain a bid or bids for completing the Contract in accordance with its terms and conditions, and upon determination by Surety of the lowest responsible bidder, or, if the Owner elects, upon determination by the Owner and the Surety jointly of the lowest responsible bidder, arrange for a contract between such bidder and Owner, and make available as Work progresses (even though there should be a default or a succession of

defaults under the contract or contracts of completion arranged under this paragraph) sufficient funds to pay the cost of completion less the balance of the contract price; but not exceeding, including other costs and damages for which the Surety may be liable hereunder, the amount set forth in the first paragraph hereof. The term "balance of the contract price," as used in this paragraph, shall mean the total amount payable by Owner to Contractor under the Contract and any amendments thereto, less the amount properly paid by Owner to Contractor.

Any suit under this bond must be instituted before the expiration of two (2) years from the date on which final payment under the Contract falls due.

No right of action shall accrue on this bond to or for the use of any person or corporation other than the Owner named herein or the heirs, executors, administrators or successors of the Owner.

Signed and sealed this

day of

20

\_\_\_\_\_  
(Witness)

\_\_\_\_\_ (Principal) (Seal)

\_\_\_\_\_  
(Title)

\_\_\_\_\_  
(Witness)

\_\_\_\_\_ (Surety) (Seal)

\_\_\_\_\_  
(Title)

# THE AMERICAN INSTITUTE OF ARCHITECTS



AIA Document A311

## Labor and Material Payment Bond

THIS BOND IS ISSUED SIMULTANEOUSLY WITH PERFORMANCE BOND IN FAVOR OF THE OWNER CONDITIONED ON THE FULL AND FAITHFUL PERFORMANCE OF THE CONTRACT

KNOW ALL MEN BY THESE PRESENTS: that

(Here insert full name and address or legal title of Contractor)

as Principal, hereinafter called Principal, and,

(Here insert full name and address or legal title of Surety)

as Surety, hereinafter called Surety, are held and firmly bound unto

(Here insert full name and address or legal title of Owner)

as Obligee; hereinafter called Owner, for the use and benefit of claimants as hereinbelow defined, in the

amount of

(Here insert a sum equal to at least one-half of the contract price)

Dollars (\$ \_\_\_\_\_),

for the payment whereof Principal and Surety bind themselves, their heirs, executors, administrators, successors and assigns, jointly and severally, firmly by these presents.

WHEREAS,

Principal has by written agreement dated \_\_\_\_\_

20 \_\_\_\_\_, entered into a contract with Owner for

(Here insert full name, address and description of project)

in accordance with Drawings and Specifications prepared by

(Here insert full name and address or legal title of Architect)

which contract is by reference made a part hereof, and is hereinafter referred to as the Contract.



# LABOR AND MATERIAL PAYMENT BOND

NOW, THEREFORE, THE CONDITION OF THIS OBLIGATION is such that, if Principal shall promptly make payment to all claimants as hereinafter defined, for all labor and material used or reasonably required for use in the performance of the Contract, then this obligation shall be void; otherwise it shall remain in full force and effect, subject, however, to the following conditions:

1. A claimant is defined as one having a direct contract with the Principal or with a Subcontractor of the Principal for labor, material, or both, used or reasonably required for use in the performance of the Contract, labor and material being construed to include that part of water, gas, power, light, heat, oil, gasoline, telephone service or rental of equipment directly applicable to the Contract.

2. The above named Principal and Surety hereby jointly and severally agree with the Owner that every claimant as herein defined, who has not been paid in full before the expiration of a period of ninety (90) days after the date on which the last of such claimant's work or labor was done or performed, or materials were furnished by such claimant, may sue on this bond for the use of such claimant, prosecute the suit to final judgment for such sum or sums as may be justly due claimant, and have execution thereon. The Owner shall not be liable for the payment of any costs or expenses of any such suit.

3. No suit or action shall be commenced hereunder by any claimant:

a) Unless claimant, other than one having a direct contract with the Principal, shall have given written notice to any two of the following: the Principal, the Owner, or the Surety above named, within ninety (90) days after such claimant did or performed the last of the work or labor, or furnished the last of the materials for which said claim is made, stating with substantial

accuracy the amount claimed and the name of the party to whom the materials were furnished, or for whom the work or labor was done or performed. Such notice shall be served by mailing the same by registered mail or certified mail, postage prepaid, in an envelope addressed to the Principal, Owner or Surety, at any place where an office is regularly maintained for the transaction of business, or served in any manner in which legal process may be served in the state in which the aforesaid project is located, save that such service need not be made by a public officer.

b) After the expiration of one (1) year following the date on which Principal ceased Work on said Contract, it being understood, however, that if any limitation embodied in this bond is prohibited by any law controlling the construction hereof such limitation shall be deemed to be amended so as to be equal to the minimum period of limitation permitted by such law.

c) Other than in a state court of competent jurisdiction in and for the county or other political subdivision of the state in which the Project, or any part thereof, is situated, or in the United States District Court for the district in which the Project, or any part thereof, is situated, and not elsewhere.

4. The amount of this bond shall be reduced by and to the extent of any payment or payments made in good faith hereunder, inclusive of the payment by Surety of mechanics' liens which may be filed of record against said improvement, whether or not claim for the amount of such lien be presented under and against this bond.

Signed and sealed this

day of

20

\_\_\_\_\_  
(Witness)

\_\_\_\_\_ (Principal) (Seal)  
\_\_\_\_\_ (Title)

\_\_\_\_\_ (Witness)

\_\_\_\_\_ (Surety) (Seal)  
\_\_\_\_\_ (Title)

# THE AMERICAN INSTITUTE OF ARCHITECTS



AIA Document A201

## General Conditions of the Contract for Construction

*THIS DOCUMENT HAS IMPORTANT LEGAL CONSEQUENCES; CONSULTATION  
WITH AN ATTORNEY IS ENCOURAGED WITH RESPECT TO ITS MODIFICATION*

### 1976 EDITION TABLE OF ARTICLES

- |  |   |
|--|---|
| 1. CONTRACT DOCUMENTS                          | 8. TIME                                   |
| 2. ARCHITECT                                   | 9. PAYMENTS AND COMPLETION                |
| 3. OWNER                                       | 10. PROTECTION OF PERSONS AND<br>PROPERTY |
| 4. CONTRACTOR                                  | 11. INSURANCE                             |
| 5. SUBCONTRACTORS                              | 12. CHANGES IN THE WORK                   |
| 6. WORK BY OWNER OR BY<br>SEPARATE CONTRACTORS | 13. UNCOVERING AND CORRECTION<br>OF WORK  |
| 7. MISCELLANEOUS PROVISIONS                    | 14. TERMINATION OF THE CONTRACT           |

This document has been approved and endorsed by The Associated General Contractors of America.

Copyright 1911, 1915, 1918, 1925, 1937, 1951, 1958, 1961, 1963, 1966, 1967, 1970, © 1976 by The American Institute of Architects, 1735 New York Avenue, N.W., Washington, D. C. 20006. Reproduction of the material herein or substantial quotation of its provisions without permission of the AIA violates the copyright laws of the United States and will be subject to legal prosecution.

## INDEX

- Acceptance of Defective or Non-Conforming Work . . . 6.2.2, 13.3  
 Acceptance of Work . . . . . 5.4.2, 9.5.5, 9.8.1, 9.9.1, 9.9.3  
 Access to Work . . . . . 2.2.5, 6.2.1  
 Accident Prevention . . . . . 2.2.4, 10  
 Acts and Omissions . . . . . 2.2.4, 4.18.3, 7.4, 7.6.2, 8.3.1, 10.2.5  
 Additional Costs, Claims for . . . . . 12.3  
 Administration of the Contract . . . . . 2.2, 4.3.3  
 All Risk Insurance . . . . . 11.3.1  
 Allowances . . . . . 4.8  
 Applications for Payment . . . . . 2.2.6, 9.2, 9.3, 9.4, 9.5.3, 9.6.1, 9.8.2, 9.9.1, 9.9.3, 14.2.2  
 Approvals . . . . . 2.2.14, 3.4, 4.3.3, 4.5, 4.12.4 through 4.12.6, 4.12.8, 4.18.3, 7.7, 9.3.2  
 Arbitration . . . . . 2.2.7 through 2.2.13, 2.2.19, 6.2.5, 7.9, 8.3.1, 11.3.7, 11.3.8  
**ARCHITECT** . . . . . 2  
 Architect, Definition of . . . . . 2.1  
 Architect, Extent of Authority . . . . . 2.2, 3.4, 4.12.8, 5.2, 6.3, 7.7.2, 8.1.3, 8.3.1, 9.2, 9.3.1, 9.4, 9.5.3, 9.6, 9.8, 9.9.1, 9.9.3, 12.1.1, 12.1.4, 12.3.1, 12.4.1, 13.1, 13.2.1, 13.2.5, 14.2  
 Architect, Limitations of Authority and Responsibility . . . . . 2.2.2 through 2.2.4, 2.2.10 through 2.2.14, 2.2.17, 2.2.18, 4.3.3, 4.12.6, 5.2.1, 9.4.2, 9.5.4, 9.5.5, 12.4  
 Architect's Additional Services . . . . . 3.4, 7.7.2, 13.2.1, 13.2.5, 14.2.2  
 Architect's Approvals . . . . . 2.2.14, 3.4, 4.5, 4.12.6, 4.12.8, 4.18.3  
 Architect's Authority to Reject Work . . . . . 2.2.13, 4.5, 13.1.2, 13.2  
 Architect's Copyright . . . . . 1.3  
 Architect's Decisions . . . . . 2.2.7 through 2.2.13, 6.3, 7.7.2, 7.9.1, 8.3.1, 9.2, 9.4, 9.6.1, 9.8.1, 12.1.4, 12.3.1  
 Architect's Inspections . . . . . 2.2.13, 2.2.16, 9.8.1, 9.9.1  
 Architect's Instructions . . . . . 2.2.13, 2.2.15, 7.7.2, 12.4, 13.1  
 Architect's Interpretations . . . . . 2.2.7 through 2.2.10, 12.3.2  
 Architect's On-Site Observations . . . . . 2.2.3, 2.2.5, 2.2.6, 2.2.17, 7.7.1, 7.7.4, 9.4.2, 9.6.1, 9.9.1  
 Architect's Project Representative . . . . . 2.2.17, 2.2.18  
 Architect's Relationship with Contractor . . . . . 1.1.2, 2.2.4, 2.2.5, 2.2.10, 2.2.13, 4.3.3, 4.5, 4.7.3, 4.12.6, 4.18, 11.3.6  
 Architect's Relationship with Subcontractors . . . . . 1.1.2, 2.2.13, 9.5.3, 9.5.4  
 Architect's Representations . . . . . 9.4.2, 9.6.1, 9.9.1  
 Artistic Effect . . . . . 1.2.3, 2.2.11, 2.2.12, 7.9.1  
 Attorneys' Fees . . . . . 4.18.1, 6.2.5, 9.9.2  
 Award of Separate Contracts . . . . . 6.1.1  
 Award of Subcontracts and Other Contracts for Portions of the Work . . . . . 5.2  
 Bonds, Lien . . . . . 9.9.2  
 Bonds, Performance, Labor and Material Payment . . . . . 7.5, 9.9.3  
 Building Permit . . . . . 4.7  
 Certificate of Substantial Completion . . . . . 9.8.1  
 Certificates of Inspection, Testing or Approval . . . . . 7.7.3  
 Certificates of Insurance . . . . . 9.3.2, 11.1.4  
 Certificates for Payment . . . . . 2.2.6, 2.2.16, 9.4, 9.5.1, 9.5.5, 9.6.1, 9.7.1, 9.8.2, 9.9.1, 9.9.3, 12.1.4, 14.2.2  
 Change Orders . . . . . 1.1.1, 2.2.15, 3.4, 4.8.2.3, 5.2.3, 7.7.2, 8.3.1, 9.7, 9.9.3, 11.3.1, 11.3.5, 11.3.7, 12.1, 13.1.2, 13.2.5, 13.3.1  
 Change Orders, Definition of . . . . . 12.1.1  
**CHANGES IN THE WORK** . . . . . 2.2.15, 4.1.1, 12  
 Claims for Additional Cost or Time . . . . . 8.3.2, 8.3.3, 12.2.1, 12.3  
 Claims for Damages . . . . . 6.1.1, 6.2.5, 7.4, 8.3, 9.6.1.1  
 Cleaning Up . . . . . 4.15, 6.3  
 Commencement of the Work, Conditions Relating to . . . . . 3.2.1, 4.2, 4.7.1, 4.10, 5.2.1, 6.2.2, 7.5, 9.2, 11.1.4, 11.3.4  
 Commencement of the Work, Definition of . . . . . 8.1.2  
 Communications . . . . . 2.2.2, 3.2.6, 4.9.1, 4.16  
 Completion, Conditions Relating to . . . . . 2.2.16, 4.11, 4.15, 9.4.2, 9.9, 13.2.2  
**COMPLETION, PAYMENTS AND** . . . . . 9  
 Completion, Substantial . . . . . 2.2.16, 8.1.1, 8.1.3, 8.2.2, 9.8, 13.2.2  
 Compliance with Laws . . . . . 1.3, 2.1.1, 4.6, 4.7, 4.13, 7.1, 7.7, 10.2.2, 14  
**Concealed Conditions** . . . . . 12.2  
 Consent, Written . . . . . 2.2.18, 4.14.2, 7.2, 7.6.2, 9.8.1, 9.9.2, 9.9.3, 11.3.9  
 Contract, Definition of . . . . . 1.1.2  
 Contract Administration . . . . . 2.2, 4.3.3  
 Contract Award and Execution, Conditions Relating to . . . . . 4.7.1, 4.10, 5.2, 7.5, 9.2, 11.1.4, 11.3.4  
**CONTRACT DOCUMENTS** . . . . . 1  
 Contract Documents, Copies Furnished and Use of . . . . . 1.3, 3.2.5, 5.3  
 Contract Documents, Definition of . . . . . 1.1.1  
 Contract Sum, Definition of . . . . . 9.1.1  
 Contract Termination . . . . . 14  
 Contract Time, Definition of . . . . . 8.1.1  
**CONTRACTOR** . . . . . 4  
 Contractor, Definition of . . . . . 4.1, 6.1.2  
 Contractor's Employees . . . . . 4.3.2, 4.4.2, 4.8.1, 4.9, 4.18, 10.2.1 through 10.2.4, 10.2.6, 10.3, 11.1.1  
**Contractor's Liability Insurance** . . . . . 11.1  
 Contractor's Relationship with Separate Contractors and Owner's Forces . . . . . 3.2.7, 6  
 Contractor's Relationship with Subcontractors . . . . . 1.2.4, 5.2, 5.3, 9.5.2, 11.3.3, 11.3.6  
 Contractor's Relationship with the Architect . . . . . 1.1.2, 2.2.4, 2.2.5, 2.2.10, 2.2.13, 4.3.3, 4.5, 4.7.3, 4.12.6, 4.18, 11.3.6  
 Contractor's Representations . . . . . 1.2.2, 4.5, 4.12.5, 9.3.3  
 Contractor's Responsibility for Those Performing the Work . . . . . 4.3.2, 4.18, 10  
 Contractor's Review of Contract Documents . . . . . 1.2.2, 4.2, 4.7.3  
 Contractor's Right to Stop the Work . . . . . 9.7  
 Contractor's Right to Terminate the Contract . . . . . 14.1  
 Contractor's Submittals . . . . . 2.2.14, 4.10, 4.12, 5.2.1, 5.2.3, 9.2, 9.3.1, 9.8.1, 9.9.2, 9.9.3  
 Contractor's Superintendent . . . . . 4.9, 10.2.6  
 Contractor's Supervision and Construction Procedures . . . . . 1.2.4, 2.2.4, 4.3, 4.4, 10  
 Contractual Liability Insurance . . . . . 11.1.3  
 Coordination and Correlation . . . . . 1.2.2, 1.2.4, 4.3.1, 4.10.1, 4.12.5, 6.1.3, 6.2.1  
 Copies Furnished of Drawings and Specifications . . . . . 1.3, 3.2.5, 5.3  
 Correction of Work . . . . . 3.3, 3.4, 10.2.5, 13.2  
 Cost, Definition of . . . . . 12.1.4  
 Costs . . . . . 3.4, 4.8.2, 4.15.2, 5.2.3, 6.1.1, 6.2.3, 6.2.5, 6.3, 7.7.1, 7.7.2, 9.7, 11.3.1, 11.3.5, 12.1.3, 12.1.4, 12.3, 13.1.2, 13.2, 14  
**Cutting and Patching of Work** . . . . . 4.14, 6.2  
 Damage to the Work . . . . . 6.2.4, 6.2.5, 9.6.1.5, 9.8.1, 10.2.1.2, 10.3, 11.3, 13.2.6  
 Damages, Claims for . . . . . 6.1.1, 6.2.5, 7.4, 8.3.4, 9.6.1.2  
 Damages for Delay . . . . . 6.1.1, 8.3.4, 9.7  
 Day, Definition of . . . . . 8.1.4

Decisions of the Architect .....	2.2.9 through 2.2.12, 6.3, 7.7.2, 7.9.1, 8.3.1, 9.2, 9.4, 9.6.1, 9.8.1, 12.1.4, 12.3.1, 14.2.1
Defective or Non-Conforming Work, Acceptance, Rejection and Correction of .....	2.2.3, 2.2.13, 3.3, 3.4, 4.5, 6.2.2, 6.2.3, 9.6.1.1, 9.9.4.2, 13
Definitions .....	1.1, 2.1, 3.1, 4.1, 4.12.1 through 4.12.3, 5.1, 6.1.2, 8.1, 9.1.1, 12.1.1, 12.1.4
Delays and Extensions of Time .....	8.3
Disputes .....	2.2.9, 2.2.12, 2.2.19, 6.2.5, 6.3, 7.9.1
Documents and Samples at the Site .....	4.11
Drawings and Specifications, Use and Ownership of .....	1.1.1, 1.3, 3.2.5, 5.3
Emergencies .....	10.3
Employees, Contractor's .....	4.3.2, 4.4.2, 4.8.1, 4.9, 4.18, 10.2.1 through 10.2.4, 10.2.6, 10.3, 11.1.1
Equipment, Labor, Materials and .....	1.1.3, 4.4, 4.5, 4.12, 4.13, 4.15.1, 6.2.1, 9.3.2, 9.3.3, 11.3, 13.2.2, 13.2.5, 14
Execution and Progress of the Work .....	1.1.3, 1.2.3, 2.2.3, 2.2.4, 2.2.8, 4.2, 4.4.1, 4.5, 6.2.2, 7.9.3, 8.2, 8.3, 9.6.1, 10.2.3, 10.2.4, 14.2
Execution, Correlation and Intent of the Contract Documents .....	1.2, 4.7.1
Extensions of Time .....	8.3, 12.1
Failure of Payment by Owner .....	9.7, 14.1
Failure of Payment of Subcontractors .....	9.5.2, 9.6.1.3, 9.9.2, 14.2.1
Final Completion and Final Payment .....	2.2.12, 2.2.16, 9.9, 13.3.1
Financial Arrangements, Owner's .....	3.2.1
Fire and Extended Coverage Insurance .....	11.3.1
Governing Law .....	7.1
Guarantees (See Warranty and Warranties) .....	2.2.16, 4.5, 9.3.3, 9.8.1, 9.9.4, 13.2.2
Indemnification .....	4.17, 4.18, 6.2.5, 9.9.2
Identification of Contract Documents .....	1.2.1
Identification of Subcontractors and Suppliers .....	5.2.1
Information and Services Required of the Owner .....	3.2, 6, 9, 11.2, 11.3
Inspections .....	2.2.13, 2.2.16, 4.3.3, 7.7, 9.8.1, 9.9.1
Instructions to Bidders .....	1.1.1, 7.5
Instructions to the Contractor .....	2.2.2, 3.2.6, 4.8.1, 7.7.2, 12.1.2, 12.1.4
INSURANCE .....	9.8.1, 11
Insurance, Contractor's Liability .....	11.1
Insurance, Loss of Use .....	11.4
Insurance, Owner's Liability .....	11.2
Insurance, Property .....	11.3
Insurance, Stored Materials .....	9.3.2, 11.3.1
Insurance Companies, Consent to Partial Occupancy .....	11.3.9
Insurance Companies, Settlement With .....	11.3.8
Intent of the Contract Documents .....	1.2.3, 2.2.10, 2.2.13, 2.2.14, 12.4
Interest .....	7.8
Interpretations, Written .....	1.1.1, 2.2.7, 2.2.8, 2.2.10, 12.4
Labor and Materials, Equipment .....	1.1.3, 4.4, 4.5, 4.12, 4.13, 4.15.1, 6.2.1, 9.3.2, 9.3.3, 11.3, 13.2.2, 13.2.5, 14
Labor and Material Payment Bond .....	7.5
Labor Disputes .....	8.3.1
Laws and Regulations .....	1.3, 2.1., 4.6, 4.7, 4.13, 7.1, 7.7, 10.2.2, 14
Liens .....	9.3.3, 9.9.2, 9.9.4.1
Limitations of Authority .....	2.2.2, 2.2.17, 2.2.18, 11.3.8, 12.4.1
Limitations of Liability .....	2.2.10, 2.2.13, 2.2.14, 3.3, 4.2, 4.7.3, 4.12.6, 4.17, 4.18.3, 6.2.2, 7.6.2, 9.4.2, 9.9.4, 9.9.5, 10.2.5, 11.1.2, 11.3.6
Limitations of Time, General .....	2.2.8, 2.2.14, 3.2.4, 4.2, 4.7.3, 4.12.4, 4.15, 5.2.1, 5.2.3, 7.4, 7.7, 8.2, 9.5.2, 9.6, 9.8, 9.9, 11.3.4, 12.1.4, 12.4, 13.2.1, 13.2.2, 13.2.5
Limitations of Time, Specific .....	2.2.8, 2.2.12, 3.2.1, 3.4, 4.10, 5.3, 6.2.2, 7.9.2, 8.2, 8.3.2, 8.3.3, 9.2, 9.3.1, 9.4.1, 9.5.1, 9.7, 11.1.4, 11.3.1, 11.3.8, 11.3.9, 12.2, 12.3, 13.2.2, 13.2.5, 13.2.7, 14.1, 14.2.1
Limitations, Statutes of .....	7.9.2, 13.2.2, 13.2.7
Loss of Use Insurance .....	11.4
Materials, Labor, Equipment and .....	1.1.3, 4.4, 4.5, 4.12, 4.13, 4.15.1, 6.2.1, 9.3.2, 9.3.3, 11.3.1, 13.2.2, 13.2.5, 14
Materials Suppliers .....	4.12.1, 5.2.1, 9.3.3
Means, Methods, Techniques, Sequences and Procedures of Construction .....	2.2.4, 4.3.1, 9.4.2
Minor Changes in the Work .....	1.1.1, 2.2.15, 12.4
MISCELLANEOUS PROVISIONS .....	7
Modifications, Definition of .....	1.1.1
Modifications to the Contract .....	1.1.1, 1.1.2, 2.2.2, 2.2.18, 4.7.3, 7.9.3, 12
Mutual Responsibility .....	6.2
Non-Conforming Work, Acceptance of Defective or .....	13.3.1
Notice, Written .....	2.2.8, 2.2.12, 3.4, 4.2, 4.7.3, 4.7.4, 4.9, 4.12.6, 4.12.7, 4.17, 5.2.1, 7.3, 7.4, 7.7, 7.9.2, 8.1.2, 8.3.2, 8.3.3, 9.4.1, 9.6.1, 9.7, 9.9.1, 9.9.5, 10.2.6, 11.1.4, 11.3.1, 11.3.4, 11.3.5, 11.3.7, 11.3.8, 12.2, 12.3, 13.2.2, 13.2.5, 14
Notices, Permits; Fees and .....	4.7, 10.2.2
Notice of Testing and Inspections .....	7.7
Notice to Proceed .....	8.1.2
Observations, Architect's On-Site .....	2.2.3, 7.7.1, 7.7.4, 9.4.2
Observations, Contractor's .....	1.2.2, 4.2.1, 4.7.3
Occupancy .....	8.1.3, 9.5.5, 11.3.9
On-Site Inspections by the Architect .....	2.2.3, 2.2.16, 9.4.2, 9.8.1, 9.9.1
On-Site Observations by the Architect .....	2.2.3, 2.2.6, 2.2.17, 7.7.1, 7.7.4, 9.4.2, 9.6.1, 9.9.1
Orders, Written .....	3.3, 4.9, 12.1.4, 12.4.1, 13.1
OWNER .....	3
Owner, Definition of .....	3.1
Owner, Information and Services Required of the .....	3.2, 6.1.3, 6.2, 9, 11.2, 11.3
Owner's Authority .....	2.2.16, 4.8.1, 7.7.2, 9.3.1, 9.3.2, 9.8.1, 11.3.8, 12.1.2, 12.1.4
Owner's Financial Capability .....	3.2.1
Owner's Liability Insurance .....	11.2
Owner's Relationship with Subcontractors .....	1.1.2, 9.5.4
Owner's Right to Carry Out the Work .....	3.4, 13.2.4
Owner's Right to Clean Up .....	4.15.2, 6.3
Owner's Right to Perform Work and to Award Separate Contracts .....	6.1
Owner's Right to Terminate the Contract .....	14.2
Owner's Right to Stop the Work .....	3.3
Ownership and Use of Documents .....	1.1.1, 1.3, 3.2.5, 5.2.3
Patching of Work, Cutting and .....	4.14, 6.2.2
Patents, Royalties and .....	4.17.1
Payment Bond, Labor and Material .....	7.5
Payment, Applications for .....	2.2.6, 9.2, 9.3, 9.4, 9.5.3, 9.6.1, 9.8.2, 9.9.1, 9.9.3, 14.2.2
Payment, Certificates for .....	2.2.6, 2.2.16, 9.4, 9.5.1, 9.5.5, 9.6.1, 9.7.1, 9.8.2, 9.9.1, 9.9.3, 12.1.4, 14.2.2

Payment, Failure of	9.5.2, 9.6.1.3, 9.7, 9.9.2, 14
Payment, Final	2.2.12, 2.2.16, 9.9, 13.3.1
Payments, Progress	7.8, 7.9.3, 9.5.5, 9.8.2, 9.9.3, 12.1.4
<b>PAYMENTS AND COMPLETION</b>	<b>9</b>
Payments to Subcontractors	9.5.2, 9.5.3, 9.5.4, 9.6.1.3, 11.3.3, 14.2.1
Payments Withheld	9.6
Performance Bond and Labor and Material Payment Bond	7.5
Permits, Fees and Notices	3.2.3, 4.7, 4.13
<b>PERSONS AND PROPERTY, PROTECTION OF</b>	<b>10</b>
Product Data, Definition of	4.12.2
Product Data, Shop Drawings, Samples and	2.2.14, 4.2.1, 4.12
Progress and Completion	2.2.3, 7.9.3, 8.2
Progress Payments	7.8, 7.9.3, 9.5.5, 9.8.2, 9.9.3, 12.1.4
Progress Schedule	4.10
Project, Definition of	1.1.4
Project Representative	2.2.17
Property Insurance	11.3
<b>PROTECTION OF PERSONS AND PROPERTY</b>	<b>10</b>
Regulations and Laws	1.3, 2.1.1, 4.6, 4.7, 4.13, 7.1, 10.2.2, 14
Rejection of Work	2.2.13, 4.5.1, 13.2
Releases of Waivers and Liens	9.9.2, 9.9.4
Representations	1.2.2, 4.5, 4.12.5, 9.4.2, 9.6.1, 9.9.1
Representatives	2.1, 2.2.2, 2.2.17, 2.2.18, 3.1, 4.1, 4.9, 5.1, 9.3.3
Responsibility for Those Performing the Work	2.2.4, 4.3.2, 6.1.3, 6.2, 9.8.1
Retainage	9.3.1, 9.5.2, 9.8.2, 9.9.2, 9.9.3
<b>Review of Contract Documents</b>	
by the Contractor	1.2.2, 4.2, 4.7.3
Reviews of Contractor's Submittals by	
Owner and Architect	2.2.14, 4.10, 4.12, 5.2.1, 5.2.3, 9.2
Rights and Remedies	1.1.2, 2.2.12, 2.2.13, 3.3, 3.4, 5.3, 6.1, 6.3, 7.6, 7.9, 8.3.1, 9.6.1, 9.7, 10.3, 12.1.2, 12.2, 13.2.2, 14
Royalties and Patents	4.17
Safety of Persons and Property	10.2
Safety Precautions and Programs	2.2.4, 10.1
Samples, Definition of	4.12.3
Samples, Shop Drawings, Product Data and	2.2.14, 4.2, 4.12
Samples at the Site, Documents and	4.11
Schedule of Values	9.2
Schedule, Progress	4.10
Separate Contracts and Contractors	4.14.2, 6, 11.3.6, 13.1.2
Shop Drawings, Definition of	4.12.1
Shop Drawings, Product Data and Samples	2.2.14, 4.2, 4.12
Site, Use of	4.13, 6.2.1
Site Visits, Architect's	2.2.3, 2.2.5, 2.2.6, 2.2.17, 7.7.1, 7.7.4, 9.4.2, 9.6.1, 9.9.1
Site Inspections	1.2.2, 2.2.3, 2.2.16, 7.7, 9.8.1, 9.9.1
Special Inspection and Testing	2.2.13, 7.7
Specifications	1.1.1, 1.2.4, 1.3
Statutes of Limitations	7.9.2, 13.2.2, 13.2.7
Stopping the Work	3.3, 9.7.1, 10.3, 14.1
Stored Materials	6.2.1, 9.3.2, 10.2.1.2, 11.3.1, 13.2.5

<b>SUBCONTRACTORS</b>	<b>5</b>
Subcontractors, Definition of	5.1
Subcontractors, Work by	1.2.4, 2.2.4, 4.3.1, 4.3.2
Subcontractual Relations	5.3
Submittals	1.3, 4.10, 4.12, 5.2.1, 5.2.3, 9.2, 9.3.1, 9.8.1, 9.9.2, 9.9.3
Subrogation, Waiver of	11.3.6
Substantial Completion	2.2.16, 8.1.1, 8.1.3, 8.2.2, 9.8, 13.2.2
Substantial Completion, Definition of	8.1.3
Substitution of Subcontractors	5.2.3, 5.2.4
Substitution of the Architect	2.2.19
Substitutions of Materials	4.5, 12.1.4
Sub-subcontractors, Definition of	5.1.2
Subsurface Conditions	12.2.1
Successors and Assigns	7.2
Supervision and Construction Procedures	1.2.4, 2.2.4, 4.3, 4.4, 10
Superintendent, Contractor's	4.9, 10.2.6
Surety, Consent of	9.9.2, 9.9.3
Surveys	3.2.2, 4.18.3
Taxes	4.6
Termination by the Contractor	14.1
Termination by the Owner	14.2
Termination of the Architect	2.2.19
<b>TERMINATION OF THE CONTRACT</b>	<b>14</b>
Tests	2.2.13, 4.3.3, 7.7, 9.4.2
Time	8
Time, Definition of	8.1
Time, Delays and Extensions of	8.3, 12.1, 12.3, 13.2.7
Time Limits, Specific	2.2.8, 2.2.12, 3.2.1, 3.4, 4.10, 5.3, 6.2.2, 7.9.2, 8.2, 8.3.2, 8.3.3, 9.2, 9.3.1, 9.4.1, 9.5.1, 9.7, 11.1.4, 11.3.1, 11.3.8, 11.3.9, 12.2, 12.3, 13.2.2, 13.2.5, 13.2.7, 14.1, 14.2.1
Title to Work	9.3.2, 9.3.3
<b>UNCOVERING AND CORRECTION OF WORK</b>	<b>13</b>
Uncovering of Work	13.1
Unforeseen Conditions	8.3, 12.2
Unit Prices	12.1.3, 12.1.5
Use of Documents	1.1.1, 1.3, 3.2.5, 5.3
Use of Site	4.13, 6.2.1
Values, Schedule of	9.2
Waiver of Claims by the Contractor	7.6.2, 8.3.2, 9.9.5, 11.3.6
Waiver of Claims by the Owner	7.6.2, 9.9.4, 11.3.6, 11.4.1
Waiver of Liens	9.9.2
Warranty and Warranties	2.2.16, 4.5, 9.3.3, 9.8.1, 9.9.4, 13.2.2
Weather Delays	8.3.1
Work, Definition of	1.1.3
Work by Owner or by Separate Contractors	6
Written Consent	2.2.18, 4.14.2, 7.2, 7.6.2, 9.8.1, 9.9.3, 9.9.4
Written Interpretations	1.1.1, 1.2.4, 2.2.8, 12.3.2
Written Notice	2.2.8, 2.2.12, 3.4, 4.2, 4.7.3, 4.7.4, 4.9, 4.12.6, 4.12.7, 4.17, 5.2.1, 7.3, 7.4, 7.7, 7.9.2, 8.1.2, 8.3.2, 8.3.3, 9.4.1, 9.6.1, 9.7, 9.9.1, 9.9.5, 10.2.6, 11.1.4, 11.3.1, 11.3.4, 11.3.5, 11.3.7, 11.3.8, 12.2, 12.3, 13.2.2, 13.2.5, 14
Written Orders	3.3; 4.9, 12.1.4, 12.4.1, 13.1

# GENERAL CONDITIONS OF THE CONTRACT FOR CONSTRUCTION

## ARTICLE 1

### CONTRACT DOCUMENTS

#### 1.1 DEFINITIONS

##### 1.1.1 THE CONTRACT DOCUMENTS

The Contract Documents consist of the Owner-Contractor Agreement, the Conditions of the Contract (General, Supplementary and other Conditions), the Drawings, the Specifications, and all Addenda issued prior to and all Modifications issued after execution of the Contract. A Modification is (1) a written amendment to the Contract signed by both parties, (2) a Change Order, (3) a written interpretation issued by the Architect pursuant to Subparagraph 2.2.8, or (4) a written order for a minor change in the Work issued by the Architect pursuant to Paragraph 12.4. The Contract Documents do not include Bidding Documents such as the Advertisement or Invitation to Bid, the Instructions to Bidders, sample forms, the Contractor's Bid or portions of Addenda relating to any of these, or any other documents, unless specifically enumerated in the Owner-Contractor Agreement.

##### 1.1.2 THE CONTRACT

The Contract Documents form the Contract for Construction. This Contract represents the entire and integrated agreement between the parties hereto and supersedes all prior negotiations, representations, or agreements, either written or oral. The Contract may be amended or modified only by a Modification as defined in Subparagraph 1.1.1. The Contract Documents shall not be construed to create any contractual relationship of any kind between the Architect and the Contractor, but the Architect shall be entitled to performance of obligations intended for his benefit, and to enforcement thereof. Nothing contained in the Contract Documents shall create any contractual relationship between the Owner or the Architect and any Subcontractor or Sub-subcontractor.

##### 1.1.3 THE WORK

The Work comprises the completed construction required by the Contract Documents and includes all labor necessary to produce such construction, and all materials and equipment incorporated or to be incorporated in such construction.

##### 1.1.4 THE PROJECT

The Project is the total construction of which the Work performed under the Contract Documents may be the whole or a part.

#### 1.2 EXECUTION, CORRELATION AND INTENT

1.2.1 The Contract Documents shall be signed in not less than triplicate by the Owner and Contractor. If either the Owner or the Contractor or both do not sign the Conditions of the Contract, Drawings, Specifications, or any of the other Contract Documents, the Architect shall identify such Documents.

1.2.2 By executing the Contract, the Contractor represents that he has visited the site, familiarized himself with the local conditions under which the Work is to be performed, and correlated his observations with the requirements of the Contract Documents.

1.2.3 The intent of the Contract Documents is to include all items necessary for the proper execution and completion of the Work. The Contract Documents are complementary, and what is required by any one shall be as binding as if required by all. Work not covered in the Contract Documents will not be required unless it is consistent therewith and is reasonably inferable therefrom as being necessary to produce the intended results. Words and abbreviations which have well-known technical or trade meanings are used in the Contract Documents in accordance with such recognized meanings.

1.2.4 The organization of the Specifications into divisions, sections and articles, and the arrangement of Drawings shall not control the Contractor in dividing the Work among Subcontractors or in establishing the extent of Work to be performed by any trade.

#### 1.3 OWNERSHIP AND USE OF DOCUMENTS

1.3.1 All Drawings, Specifications and copies thereof furnished by the Architect are and shall remain his property. They are to be used only with respect to this Project and are not to be used on any other project. With the exception of one contract set for each party to the Contract, such documents are to be returned or suitably accounted for to the Architect on request at the completion of the Work. Submission or distribution to meet official regulatory requirements or for other purposes in connection with the Project is not to be construed as publication in derogation of the Architect's common law copyright or other reserved rights.

## ARTICLE 2

### ARCHITECT

#### 2.1 DEFINITION

2.1.1 The Architect is the person lawfully licensed to practice architecture, or an entity lawfully practicing architecture identified as such in the Owner-Contractor Agreement, and is referred to throughout the Contract Documents as if singular in number and masculine in gender. The term Architect means the Architect or his authorized representative.

#### 2.2 ADMINISTRATION OF THE CONTRACT

2.2.1 The Architect will provide administration of the Contract as hereinafter described.

2.2.2 The Architect will be the Owner's representative during construction and until final payment is due. The Architect will advise and consult with the Owner. The Owner's instructions to the Contractor shall be forwarded

through the Architect. The Architect will have authority to act on behalf of the Owner only to the extent provided in the Contract Documents, unless otherwise modified by written instrument in accordance with Subparagraph 2.2.18.

2.2.3 The Architect will visit the site at intervals appropriate to the stage of construction to familiarize himself generally with the progress and quality of the Work and to determine in general if the Work is proceeding in accordance with the Contract Documents. However, the Architect will not be required to make exhaustive or continuous on-site inspections to check the quality or quantity of the Work. On the basis of his on-site observations as an architect, he will keep the Owner informed of the progress of the Work, and will endeavor to guard the Owner against defects and deficiencies in the Work of the Contractor.

2.2.4 The Architect will not be responsible for and will not have control or charge of construction means, methods, techniques, sequences or procedures, or for safety precautions and programs in connection with the Work, and he will not be responsible for the Contractor's failure to carry out the Work in accordance with the Contract Documents. The Architect will not be responsible for or have control or charge over the acts or omissions of the Contractor, Subcontractors, or any of their agents or employees, or any other persons performing any of the Work.

2.2.5 The Architect shall at all times have access to the Work wherever it is in preparation and progress. The Contractor shall provide facilities for such access so the Architect may perform his functions under the Contract Documents.

2.2.6 Based on the Architect's observations and an evaluation of the Contractor's Applications for Payment, the Architect will determine the amounts owing to the Contractor and will issue Certificates for Payment in such amounts, as provided in Paragraph 9.4.

2.2.7 The Architect will be the interpreter of the requirements of the Contract Documents and the judge of the performance thereunder by both the Owner and Contractor.

2.2.8 The Architect will render interpretations necessary for the proper execution or progress of the Work, with reasonable promptness and in accordance with any time limit agreed upon. Either party to the Contract may make written request to the Architect for such interpretations.

2.2.9 Claims, disputes and other matters in question between the Contractor and the Owner relating to the execution or progress of the Work or the interpretation of the Contract Documents shall be referred initially to the Architect for decision which he will render in writing within a reasonable time.

2.2.10 All interpretations and decisions of the Architect shall be consistent with the intent of and reasonably inferable from the Contract Documents and will be in writing or in the form of drawings. In his capacity as interpreter and judge, he will endeavor to secure faithful performance by both the Owner and the Contractor, will not

show partiality to either, and will not be liable for the result of any interpretation or decision rendered in good faith in such capacity.

2.2.11 The Architect's decisions in matters relating to artistic effect will be final if consistent with the intent of the Contract Documents.

2.2.12 Any claim, dispute or other matter in question between the Contractor and the Owner referred to the Architect, except those relating to artistic effect as provided in Subparagraph 2.2.11 and except those which have been waived by the making or acceptance of final payment as provided in Subparagraphs 9.9.4 and 9.9.5, shall be subject to arbitration upon the written demand of either party. However, no demand for arbitration of any such claim, dispute or other matter may be made until the earlier of (1) the date on which the Architect has rendered a written decision, or (2) the tenth day after the parties have presented their evidence to the Architect or have been given a reasonable opportunity to do so, if the Architect has not rendered his written decision by that date. When such a written decision of the Architect states (1) that the decision is final but subject to appeal, and (2) that any demand for arbitration of a claim, dispute or other matter covered by such decision must be made within thirty days after the date on which the party making the demand receives the written decision, failure to demand arbitration within said thirty days' period will result in the Architect's decision becoming final and binding upon the Owner and the Contractor. If the Architect renders a decision after arbitration proceedings have been initiated, such decision may be entered as evidence but will not supersede any arbitration proceedings unless the decision is acceptable to all parties concerned.

2.2.13 The Architect will have authority to reject Work which does not conform to the Contract Documents. Whenever, in his opinion, he considers it necessary or advisable for the implementation of the intent of the Contract Documents, he will have authority to require special inspection or testing of the Work in accordance with Subparagraph 7.7.2 whether or not such Work be then fabricated, installed or completed. However, neither the Architect's authority to act under this Subparagraph 2.2.13, nor any decision made by him in good faith either to exercise or not to exercise such authority, shall give rise to any duty or responsibility of the Architect to the Contractor, any Subcontractor, any of their agents or employees, or any other person performing any of the Work.

2.2.14 The Architect will review and approve or take other appropriate action upon Contractor's submittals such as Shop Drawings, Product Data and Samples, but only for conformance with the design concept of the Work and with the information given in the Contract Documents. Such action shall be taken with reasonable promptness so as to cause no delay. The Architect's approval of a specific item shall not indicate approval of an assembly of which the item is a component.

2.2.15 The Architect will prepare Change Orders in accordance with Article 12, and will have authority to order minor changes in the Work as provided in Subparagraph 12.4.1.

2.2.16 The Architect will conduct inspections to determine the dates of Substantial Completion and final completion, will receive and forward to the Owner for the Owner's review written warranties and related documents required by the Contract and assembled by the Contractor, and will issue a final Certificate for Payment upon compliance with the requirements of Paragraph 9.9.

2.2.17 If the Owner and Architect agree, the Architect will provide one or more Project Representatives to assist the Architect in carrying out his responsibilities at the site. The duties, responsibilities and limitations of authority of any such Project Representative shall be as set forth in an exhibit to be incorporated in the Contract Documents.

2.2.18 The duties, responsibilities and limitations of authority of the Architect as the Owner's representative during construction as set forth in the Contract Documents will not be modified or extended without written consent of the Owner, the Contractor and the Architect.

2.2.19 In case of the termination of the employment of the Architect, the Owner shall appoint an architect against whom the Contractor makes no reasonable objection whose status under the Contract Documents shall be that of the former architect. Any dispute in connection with such appointment shall be subject to arbitration.

### ARTICLE 3

#### OWNER

##### 3.1 DEFINITION

3.1.1 The Owner is the person or entity identified as such in the Owner-Contractor Agreement and is referred to throughout the Contract Documents as if singular in number and masculine in gender. The term Owner means the Owner or his authorized representative.

##### 3.2 INFORMATION AND SERVICES REQUIRED OF THE OWNER

3.2.1 The Owner shall, at the request of the Contractor, at the time of execution of the Owner-Contractor Agreement, furnish to the Contractor reasonable evidence that he has made financial arrangements to fulfill his obligations under the Contract. Unless such reasonable evidence is furnished, the Contractor is not required to execute the Owner-Contractor Agreement or to commence the Work.

3.2.2 The Owner shall furnish all surveys describing the physical characteristics, legal limitations and utility locations for the site of the Project, and a legal description of the site.

3.2.3 Except as provided in Subparagraph 4.7.1, the Owner shall secure and pay for necessary approvals, easements, assessments and charges required for the construction, use or occupancy of permanent structures or for permanent changes in existing facilities.

3.2.4 Information or services under the Owner's control shall be furnished by the Owner with reasonable promptness to avoid delay in the orderly progress of the Work.

3.2.5 Unless otherwise provided in the Contract Documents, the Contractor will be furnished, free of charge, all copies of Drawings and Specifications reasonably necessary for the execution of the Work.

3.2.6 The Owner shall forward all instructions to the Contractor through the Architect.

3.2.7 The foregoing are in addition to other duties and responsibilities of the Owner enumerated herein and especially those in respect to Work by Owner or by Separate Contractors, Payments and Completion, and Insurance in Articles 6, 9 and 11 respectively.

##### 3.3 OWNER'S RIGHT TO STOP THE WORK

3.3.1 If the Contractor fails to correct defective Work as required by Paragraph 13.2 or persistently fails to carry out the Work in accordance with the Contract Documents, the Owner, by a written order signed personally or by an agent specifically so empowered by the Owner in writing, may order the Contractor to stop the Work, or any portion thereof, until the cause for such order has been eliminated; however, this right of the Owner to stop the Work shall not give rise to any duty on the part of the Owner to exercise this right for the benefit of the Contractor or any other person or entity, except to the extent required by Subparagraph 6.1.3.

##### 3.4 OWNER'S RIGHT TO CARRY OUT THE WORK

3.4.1 If the Contractor defaults or neglects to carry out the Work in accordance with the Contract Documents and fails within seven days after receipt of written notice from the Owner to commence and continue correction of such default or neglect with diligence and promptness, the Owner may, after seven days following receipt by the Contractor of an additional written notice and without prejudice to any other remedy he may have, make good such deficiencies. In such case an appropriate Change Order shall be issued deducting from the payments then or thereafter due the Contractor the cost of correcting such deficiencies, including compensation for the Architect's additional services made necessary by such default, neglect or failure. Such action by the Owner and the amount charged to the Contractor are both subject to the prior approval of the Architect. If the payments then or thereafter due the Contractor are not sufficient to cover such amount, the Contractor shall pay the difference to the Owner.

### ARTICLE 4

#### CONTRACTOR

##### 4.1 DEFINITION

4.1.1 The Contractor is the person or entity identified as such in the Owner-Contractor Agreement and is referred to throughout the Contract Documents as if singular in number and masculine in gender. The term Contractor means the Contractor or his authorized representative.

##### 4.2 REVIEW OF CONTRACT DOCUMENTS

4.2.1 The Contractor shall carefully study and compare the Contract Documents and shall at once report to the Architect any error, inconsistency or omission he may discover. The Contractor shall not be liable to the Owner or



the Architect for any damage resulting from any such errors, inconsistencies or omissions in the Contract Documents. The Contractor shall perform no portion of the Work at any time without Contract Documents or, where required, approved Shop Drawings, Product Data or Samples for such portion of the Work.

#### 4.3 SUPERVISION AND CONSTRUCTION PROCEDURES

4.3.1 The Contractor shall supervise and direct the Work, using his best skill and attention. He shall be solely responsible for all construction means, methods, techniques, sequences and procedures and for coordinating all portions of the Work under the Contract.

4.3.2 The Contractor shall be responsible to the Owner for the acts and omissions of his employees, Subcontractors and their agents and employees, and other persons performing any of the Work under a contract with the Contractor.

4.3.3 The Contractor shall not be relieved from his obligations to perform the Work in accordance with the Contract Documents either by the activities or duties of the Architect in his administration of the Contract, or by inspections, tests or approvals required or performed under Paragraph 7.7 by persons other than the Contractor.

#### 4.4 LABOR AND MATERIALS

4.4.1 Unless otherwise provided in the Contract Documents, the Contractor shall provide and pay for all labor, materials, equipment, tools, construction equipment and machinery, water, heat, utilities, transportation, and other facilities and services necessary for the proper execution and completion of the Work, whether temporary or permanent and whether or not incorporated or to be incorporated in the Work.

4.4.2 The Contractor shall at all times enforce strict discipline and good order among his employees and shall not employ on the Work any unfit person or anyone not skilled in the task assigned to him.

#### 4.5 WARRANTY

4.5.1 The Contractor warrants to the Owner and the Architect that all materials and equipment furnished under this Contract will be new unless otherwise specified, and that all Work will be of good quality, free from faults and defects and in conformance with the Contract Documents. All Work not conforming to these requirements, including substitutions not properly approved and authorized, may be considered defective. If required by the Architect, the Contractor shall furnish satisfactory evidence as to the kind and quality of materials and equipment. This warranty is not limited by the provisions of Paragraph 13.2.

#### 4.6 TAXES

4.6.1 The Contractor shall pay all sales, consumer, use and other similar taxes for the Work or portions thereof provided by the Contractor which are legally enacted at the time bids are received, whether or not yet effective.

#### 4.7 PERMITS, FEES AND NOTICES

4.7.1 Unless otherwise provided in the Contract Documents, the Contractor shall secure and pay for the building permit and for all other permits and governmental

fees, licenses and inspections necessary for the proper execution and completion of the Work which are customarily secured after execution of the Contract and which are legally required at the time the bids are received.

4.7.2 The Contractor shall give all notices and comply with all laws, ordinances, rules, regulations and lawful orders of any public authority bearing on the performance of the Work.

4.7.3 It is not the responsibility of the Contractor to make certain that the Contract Documents are in accordance with applicable laws, statutes, building codes and regulations. If the Contractor observes that any of the Contract Documents are at variance therewith in any respect, he shall promptly notify the Architect in writing, and any necessary changes shall be accomplished by appropriate Modification.

4.7.4 If the Contractor performs any Work knowing it to be contrary to such laws, ordinances, rules and regulations, and without such notice to the Architect, he shall assume full responsibility therefor and shall bear all costs attributable thereto.

#### 4.8 ALLOWANCES

4.8.1 The Contractor shall include in the Contract Sum all allowances stated in the Contract Documents. Items covered by these allowances shall be supplied for such amounts and by such persons as the Owner may direct, but the Contractor will not be required to employ persons against whom he makes a reasonable objection.

4.8.2 Unless otherwise provided in the Contract Documents:

- 1 these allowances shall cover the cost to the Contractor, less any applicable trade discount, of the materials and equipment required by the allowance delivered at the site, and all applicable taxes;
- 2 the Contractor's costs for unloading and handling on the site, labor, installation costs, overhead, profit and other expenses contemplated for the original allowance shall be included in the Contract Sum and not in the allowance;
- 3 whenever the cost is more than or less than the allowance, the Contract Sum shall be adjusted accordingly by Change Order, the amount of which will recognize changes, if any, in handling costs on the site, labor, installation costs, overhead, profit and other expenses.

#### 4.9 SUPERINTENDENT

4.9.1 The Contractor shall employ a competent superintendent and necessary assistants who shall be in attendance at the Project site during the progress of the Work. The superintendent shall represent the Contractor and all communications given to the superintendent shall be as binding as if given to the Contractor. Important communications shall be confirmed in writing. Other communications shall be so confirmed on written request in each case.

#### 4.10 PROGRESS SCHEDULE

4.10.1 The Contractor, immediately after being awarded the Contract, shall prepare and submit for the Owner's and Architect's information an estimated progress sched-

ule for the Work. The progress schedule shall be related to the entire Project to the extent required by the Contract Documents, and shall provide for expeditious and practicable execution of the Work.

#### 4.11 DOCUMENTS AND SAMPLES AT THE SITE

4.11.1 The Contractor shall maintain at the site for the Owner one record copy of all Drawings, Specifications, Addenda, Change Orders and other Modifications, in good order and marked currently to record all changes made during construction, and approved Shop Drawings, Product Data and Samples. These shall be available to the Architect and shall be delivered to him for the Owner upon completion of the Work.

#### 4.12 SHOP DRAWINGS, PRODUCT DATA AND SAMPLES

4.12.1 Shop Drawings are drawings, diagrams, schedules and other data specially prepared for the Work by the Contractor or any Subcontractor, manufacturer, supplier or distributor to illustrate some portion of the Work.

4.12.2 Product Data are illustrations, standard schedules, performance charts, instructions, brochures, diagrams and other information furnished by the Contractor to illustrate a material, product or system for some portion of the Work.

4.12.3 Samples are physical examples which illustrate materials, equipment or workmanship and establish standards by which the Work will be judged.

4.12.4 The Contractor shall review, approve and submit, with reasonable promptness and in such sequence as to cause no delay in the Work or in the work of the Owner or any separate contractor, all Shop Drawings, Product Data and Samples required by the Contract Documents.

4.12.5 By approving and submitting Shop Drawings, Product Data and Samples, the Contractor represents that he has determined and verified all materials, field measurements, and field construction criteria related thereto, or will do so, and that he has checked and coordinated the information contained within such submittals with the requirements of the Work and of the Contract Documents.

4.12.6 The Contractor shall not be relieved of responsibility for any deviation from the requirements of the Contract Documents by the Architect's approval of Shop Drawings, Product Data or Samples under Subparagraph 2.2.14 unless the Contractor has specifically informed the Architect in writing of such deviation at the time of submission and the Architect has given written approval to the specific deviation. The Contractor shall not be relieved from responsibility for errors or omissions in the Shop Drawings, Product Data or Samples by the Architect's approval thereof.

4.12.7 The Contractor shall direct specific attention, in writing or on resubmitted Shop Drawings, Product Data or Samples, to revisions other than those requested by the Architect on previous submittals.

4.12.8 No portion of the Work requiring submission of a Shop Drawing, Product Data or Sample shall be commenced until the submittal has been approved by the Architect as provided in Subparagraph 2.2.14. All such

portions of the Work shall be in accordance with approved submittals.

#### 4.13 USE OF SITE

4.13.1 The Contractor shall confine operations at the site to areas permitted by law, ordinances, permits and the Contract Documents and shall not unreasonably encumber the site with any materials or equipment.

#### 4.14 CUTTING AND PATCHING OF WORK

4.14.1 The Contractor shall be responsible for all cutting, fitting or patching that may be required to complete the Work or to make its several parts fit together properly.

4.14.2 The Contractor shall not damage or endanger any portion of the Work or the work of the Owner or any separate contractors by cutting, patching or otherwise altering any work, or by excavation. The Contractor shall not cut or otherwise alter the work of the Owner or any separate contractor except with the written consent of the Owner and of such separate contractor. The Contractor shall not unreasonably withhold from the Owner or any separate contractor his consent to cutting or otherwise altering the Work.

#### 4.15 CLEANING UP

4.15.1 The Contractor at all times shall keep the premises free from accumulation of waste materials or rubbish caused by his operations. At the completion of the Work he shall remove all his waste materials and rubbish from and about the Project as well as all his tools, construction equipment, machinery and surplus materials.

4.15.2 If the Contractor fails to clean up at the completion of the Work, the Owner may do so as provided in Paragraph 3.4 and the cost thereof shall be charged to the Contractor.

#### 4.16 COMMUNICATIONS

4.16.1 The Contractor shall forward all communications to the Owner through the Architect.

#### 4.17 ROYALTIES AND PATENTS

4.17.1 The Contractor shall pay all royalties and license fees. He shall defend all suits or claims for infringement of any patent rights and shall save the Owner harmless from loss on account thereof, except that the Owner shall be responsible for all such loss when a particular design, process or the product of a particular manufacturer or manufacturers is specified, but if the Contractor has reason to believe that the design, process or product specified is an infringement of a patent, he shall be responsible for such loss unless he promptly gives such information to the Architect.

#### 4.18 INDEMNIFICATION

4.18.1 To the fullest extent permitted by law, the Contractor shall indemnify and hold harmless the Owner and the Architect and their agents and employees from and against all claims, damages, losses and expenses, including but not limited to attorneys' fees, arising out of or resulting from the performance of the Work, provided that any such claim, damage, loss or expense (1) is attributable to bodily injury, sickness, disease or death, or to injury to or destruction of tangible property (other than the Work itself) including the loss of use resulting therefrom,

and (2) is caused in whole or in part by any negligent act or omission of the Contractor, any Subcontractor, anyone directly or indirectly employed by any of them or anyone for whose acts any of them may be liable, regardless of whether or not it is caused in part by a party indemnified hereunder. Such obligation shall not be construed to negate, abridge, or otherwise reduce any other right or obligation of indemnity which would otherwise exist as to any party or person described in this Paragraph 4.18.

**4.18.2** In any and all claims against the Owner or the Architect or any of their agents or employees by any employee of the Contractor, any Subcontractor, anyone directly or indirectly employed by any of them or anyone for whose acts any of them may be liable, the indemnification obligation under this Paragraph 4.18 shall not be limited in any way by any limitation on the amount or type of damages, compensation or benefits payable by or for the Contractor or any Subcontractor under workers' or workmen's compensation acts, disability benefit acts or other employee benefit acts.

**4.18.3** The obligations of the Contractor under this Paragraph 4.18 shall not extend to the liability of the Architect, his agents or employees, arising out of (1) the preparation or approval of maps, drawings, opinions, reports, surveys, change orders, designs or specifications, or (2) the giving of or the failure to give directions or instructions by the Architect, his agents or employees provided such giving or failure to give is the primary cause of the injury or damage.

## ARTICLE 5

### SUBCONTRACTORS

#### 5.1 DEFINITION

**5.1.1** A Subcontractor is a person or entity who has a direct contract with the Contractor to perform any of the Work at the site. The term Subcontractor is referred to throughout the Contract Documents as if singular in number and masculine in gender and means a Subcontractor or his authorized representative. The term Subcontractor does not include any separate contractor or his subcontractors.

**5.1.2** A Sub-subcontractor is a person or entity who has a direct or indirect contract with a Subcontractor to perform any of the Work at the site. The term Sub-subcontractor is referred to throughout the Contract Documents as if singular in number and masculine in gender and means a Sub-subcontractor or an authorized representative thereof.

#### 5.2 AWARD OF SUBCONTRACTS AND OTHER CONTRACTS FOR PORTIONS OF THE WORK

**5.2.1** Unless otherwise required by the Contract Documents or the Bidding Documents, the Contractor, as soon as practicable after the award of the Contract, shall furnish to the Owner and the Architect in writing the names of the persons or entities (including those who are to furnish materials or equipment fabricated to a special design) proposed for each of the principal portions of the Work. The Architect will promptly reply to the Contractor in writing stating whether or not the Owner or the Architect, after due investigation, has reasonable objection to any

such proposed person or entity. Failure of the Owner or Architect to reply promptly shall constitute notice of no reasonable objection.

**5.2.2** The Contractor shall not contract with any such proposed person or entity to whom the Owner or the Architect has made reasonable objection under the provisions of Subparagraph 5.2.1. The Contractor shall not be required to contract with anyone to whom he has a reasonable objection.

**5.2.3** If the Owner or the Architect has reasonable objection to any such proposed person or entity, the Contractor shall submit a substitute to whom the Owner or the Architect has no reasonable objection, and the Contract Sum shall be increased or decreased by the difference in cost occasioned by such substitution and an appropriate Change Order shall be issued; however, no increase in the Contract Sum shall be allowed for any such substitution unless the Contractor has acted promptly and responsibly in submitting names as required by Subparagraph 5.2.1.

**5.2.4** The Contractor shall make no substitution for any Subcontractor, person or entity previously selected if the Owner or Architect makes reasonable objection to such substitution.

#### 5.3 SUBCONTRACTUAL RELATIONS

**5.3.1** By an appropriate agreement, written where legally required for validity, the Contractor shall require each Subcontractor, to the extent of the Work to be performed by the Subcontractor, to be bound to the Contractor by the terms of the Contract Documents, and to assume toward the Contractor all the obligations and responsibilities which the Contractor, by these Documents, assumes toward the Owner and the Architect. Said agreement shall preserve and protect the rights of the Owner and the Architect under the Contract Documents with respect to the Work to be performed by the Subcontractor so that the subcontracting thereof will not prejudice such rights, and shall allow to the Subcontractor, unless specifically provided otherwise in the Contractor-Subcontractor agreement, the benefit of all rights, remedies and redress against the Contractor that the Contractor, by these Documents, has against the Owner. Where appropriate, the Contractor shall require each Subcontractor to enter into similar agreements with his Sub-subcontractors. The Contractor shall make available to each proposed Subcontractor, prior to the execution of the Subcontract, copies of the Contract Documents to which the Subcontractor will be bound by this Paragraph 5.3, and identify to the Subcontractor any terms and conditions of the proposed Subcontract which may be at variance with the Contract Documents. Each Subcontractor shall similarly make copies of such Documents available to his Sub-subcontractors.

## ARTICLE 6

### WORK BY OWNER OR BY SEPARATE CONTRACTORS

#### 6.1 OWNER'S RIGHT TO PERFORM WORK AND TO AWARD SEPARATE CONTRACTS

**6.1.1** The Owner reserves the right to perform work related to the Project with his own forces, and to award

separate contracts in connection with other portions of the Project or other work on the site under these or similar Conditions of the Contract. If the Contractor claims that delay or additional cost is involved because of such action by the Owner, he shall make such claim as provided elsewhere in the Contract Documents.

6.1.2 When separate contracts are awarded for different portions of the Project or other work on the site, the term Contractor in the Contract Documents in each case shall mean the Contractor who executes each separate Owner-Contractor Agreement.

6.1.3 The Owner will provide for the coordination of the work of his own forces and of each separate contractor with the Work of the Contractor, who shall cooperate therewith as provided in Paragraph 6.2.

## 6.2 MUTUAL RESPONSIBILITY

6.2.1 The Contractor shall afford the Owner and separate contractors reasonable opportunity for the introduction and storage of their materials and equipment and the execution of their work, and shall connect and coordinate his Work with theirs as required by the Contract Documents.

6.2.2 If any part of the Contractor's Work depends for proper execution or results upon the work of the Owner or any separate contractor, the Contractor shall, prior to proceeding with the Work, promptly report to the Architect any apparent discrepancies or defects in such other work that render it unsuitable for such proper execution and results. Failure of the Contractor so to report shall constitute an acceptance of the Owner's or separate contractors' work as fit and proper to receive his Work, except as to defects which may subsequently become apparent in such work by others.

6.2.3 Any costs caused by defective or ill-timed work shall be borne by the party responsible therefor.

6.2.4 Should the Contractor wrongfully cause damage to the work or property of the Owner, or to other work on the site, the Contractor shall promptly remedy such damage as provided in Subparagraph 10.2.5.

6.2.5 Should the Contractor wrongfully cause damage to the work or property of any separate contractor, the Contractor shall upon due notice promptly attempt to settle with such other contractor by agreement, or otherwise to resolve the dispute. If such separate contractor sues or initiates an arbitration proceeding against the Owner on account of any damage alleged to have been caused by the Contractor, the Owner shall notify the Contractor who shall defend such proceedings at the Owner's expense, and if any judgment or award against the Owner arises therefrom the Contractor shall pay or satisfy it and shall reimburse the Owner for all attorneys' fees and court or arbitration costs which the Owner has incurred.

## 6.3 OWNER'S RIGHT TO CLEAN UP

6.3.1 If a dispute arises between the Contractor and separate contractors as to their responsibility for cleaning up as required by Paragraph 4.15, the Owner may clean up

and charge the cost thereof to the contractors responsible therefor as the Architect shall determine to be just.

## ARTICLE 7

### MISCELLANEOUS PROVISIONS

#### 7.1 GOVERNING LAW

7.1.1 The Contract shall be governed by the law of the place where the Project is located.

#### 7.2 SUCCESSORS AND ASSIGNS

7.2.1 The Owner and the Contractor each binds himself, his partners, successors, assigns and legal representatives to the other party hereto and to the partners, successors, assigns and legal representatives of such other party in respect to all covenants, agreements and obligations contained in the Contract Documents. Neither party to the Contract shall assign the Contract or sublet it as a whole without the written consent of the other, nor shall the Contractor assign any moneys due or to become due to him hereunder, without the previous written consent of the Owner.

#### 7.3 WRITTEN NOTICE

7.3.1 Written notice shall be deemed to have been duly served if delivered in person to the individual or member of the firm or entity or to an officer of the corporation for whom it was intended, or if delivered at or sent by registered or certified mail to the last business address known to him who gives the notice.

#### 7.4 CLAIMS FOR DAMAGES

7.4.1 Should either party to the Contract suffer injury or damage to person or property because of any act or omission of the other party or of any of his employees, agents or others for whose acts he is legally liable, claim shall be made in writing to such other party within a reasonable time after the first observance of such injury or damage.

#### 7.5 PERFORMANCE BOND AND LABOR AND MATERIAL PAYMENT BOND

7.5.1 The Owner shall have the right to require the Contractor to furnish bonds covering the faithful performance of the Contract and the payment of all obligations arising thereunder if and as required in the Bidding Documents or in the Contract Documents.

#### 7.6 RIGHTS AND REMEDIES

7.6.1 The duties and obligations imposed by the Contract Documents and the rights and remedies available thereunder shall be in addition to and not a limitation of any duties, obligations, rights and remedies otherwise imposed or available by law.

7.6.2 No action or failure to act by the Owner, Architect or Contractor shall constitute a waiver of any right or duty afforded any of them under the Contract, nor shall any such action or failure to act constitute an approval of or acquiescence in any breach thereunder, except as may be specifically agreed in writing.

## 7.7 TESTS

7.7.1 If the Contract Documents, laws, ordinances, rules, regulations or orders of any public authority having jurisdiction require any portion of the Work to be inspected, tested or approved, the Contractor shall give the Architect timely notice of its readiness so the Architect may observe such inspection, testing or approval. The Contractor shall bear all costs of such inspections, tests or approvals conducted by public authorities. Unless otherwise provided, the Owner shall bear all costs of other inspections, tests or approvals.

7.7.2 If the Architect determines that any Work requires special inspection, testing, or approval which Subparagraph 7.7.1 does not include, he will, upon written authorization from the Owner, instruct the Contractor to order such special inspection, testing or approval, and the Contractor shall give notice as provided in Subparagraph 7.7.1. If such special inspection or testing reveals a failure of the Work to comply with the requirements of the Contract Documents, the Contractor shall bear all costs thereof, including compensation for the Architect's additional services made necessary by such failure; otherwise the Owner shall bear such costs, and an appropriate Change Order shall be issued.

7.7.3 Required certificates of inspection, testing or approval shall be secured by the Contractor and promptly delivered by him to the Architect.

7.7.4 If the Architect is to observe the inspections, tests or approvals required by the Contract Documents, he will do so promptly and, where practicable, at the source of supply.

## 7.8 INTEREST

7.8.1 Payments due and unpaid under the Contract Documents shall bear interest from the date payment is due at such rate as the parties may agree upon in writing or, in the absence thereof, at the legal rate prevailing at the place of the Project.

## 7.9 ARBITRATION

7.9.1 All claims, disputes and other matters in question between the Contractor and the Owner arising out of, or relating to, the Contract Documents or the breach thereof, except as provided in Subparagraph 2.2.11 with respect to the Architect's decisions on matters relating to artistic effect, and except for claims which have been waived by the making or acceptance of final payment as provided by Subparagraphs 9.9.4 and 9.9.5, shall be decided by arbitration in accordance with the Construction Industry Arbitration Rules of the American Arbitration Association then obtaining unless the parties mutually agree otherwise. No arbitration arising out of or relating to the Contract Documents shall include, by consolidation, joinder or in any other manner, the Architect, his employees or consultants except by written consent containing a specific reference to the Owner-Contractor Agreement and signed by the Architect, the Owner, the Contractor and any other person sought to be joined. No arbitration shall include by consolidation, joinder or in any other manner, parties other than the Owner, the Contractor and any other persons substantially involved in a common question of fact or law, whose presence is

required if complete relief is to be accorded in the arbitration. No person other than the Owner or Contractor shall be included as an original third party or additional third party to an arbitration whose interest or responsibility is insubstantial. Any consent to arbitration involving an additional person or persons shall not constitute consent to arbitration of any dispute not described therein or with any person not named or described therein. The foregoing agreement to arbitrate and any other agreement to arbitrate with an additional person or persons duly consented to by the parties to the Owner-Contractor Agreement shall be specifically enforceable under the prevailing arbitration law. The award rendered by the arbitrators shall be final, and judgment may be entered upon it in accordance with applicable law in any court having jurisdiction thereof.

7.9.2 Notice of the demand for arbitration shall be filed in writing with the other party to the Owner-Contractor Agreement and with the American Arbitration Association, and a copy shall be filed with the Architect. The demand for arbitration shall be made within the time limits specified in Subparagraph 2.2.12 where applicable, and in all other cases within a reasonable time after the claim, dispute or other matter in question has arisen, and in no event shall it be made after the date when institution of legal or equitable proceedings based on such claim, dispute or other matter in question would be barred by the applicable statute of limitations.

7.9.3 Unless otherwise agreed in writing, the Contractor shall carry on the Work and maintain its progress during any arbitration proceedings, and the Owner shall continue to make payments to the Contractor in accordance with the Contract Documents.

## ARTICLE 8

### TIME

#### 8.1 DEFINITIONS

8.1.1 Unless otherwise provided, the Contract Time is the period of time allotted in the Contract Documents for Substantial Completion of the Work as defined in Subparagraph 8.1.3, including authorized adjustments thereto.

8.1.2 The date of commencement of the Work is the date established in a notice to proceed. If there is no notice to proceed, it shall be the date of the Owner-Contractor Agreement or such other date as may be established therein.

8.1.3 The Date of Substantial Completion of the Work or designated portion thereof is the Date certified by the Architect when construction is sufficiently complete, in accordance with the Contract Documents, so the Owner can occupy or utilize the Work or designated portion thereof for the use for which it is intended.

8.1.4 The term day as used in the Contract Documents shall mean calendar day unless otherwise specifically designated.

#### 8.2 PROGRESS AND COMPLETION

8.2.1 All time limits stated in the Contract Documents are of the essence of the Contract.

8.2.2 The Contractor shall begin the Work on the date of commencement as defined in Subparagraph 8.1.2. He shall carry the Work forward expeditiously with adequate forces and shall achieve Substantial Completion within the Contract Time.

### 8.3 DELAYS AND EXTENSIONS OF TIME

8.3.1 If the Contractor is delayed at any time in the progress of the Work by any act or neglect of the Owner or the Architect, or by any employee of either, or by any separate contractor employed by the Owner, or by changes ordered in the Work, or by labor disputes, fire, unusual delay in transportation, adverse weather conditions not reasonably anticipatable, unavoidable casualties, or any causes beyond the Contractor's control, or by delay authorized by the Owner pending arbitration, or by any other cause which the Architect determines may justify the delay, then the Contract Time shall be extended by Change Order for such reasonable time as the Architect may determine.

8.3.2 Any claim for extension of time shall be made in writing to the Architect not more than twenty days after the commencement of the delay; otherwise it shall be waived. In the case of a continuing delay only one claim is necessary. The Contractor shall provide an estimate of the probable effect of such delay on the progress of the Work.

8.3.3 If no agreement is made stating the dates upon which interpretations as provided in Subparagraph 2.2.8 shall be furnished, then no claim for delay shall be allowed on account of failure to furnish such interpretations until fifteen days after written request is made for them, and not then unless such claim is reasonable.

8.3.4 This Paragraph 8.3 does not exclude the recovery of damages for delay by either party under other provisions of the Contract Documents.

## ARTICLE 9

### PAYMENTS AND COMPLETION

#### 9.1 CONTRACT SUM

9.1.1 The Contract Sum is stated in the Owner-Contractor Agreement and, including authorized adjustments thereto, is the total amount payable by the Owner to the Contractor for the performance of the Work under the Contract Documents.

#### 9.2 SCHEDULE OF VALUES

9.2.1 Before the first Application for Payment, the Contractor shall submit to the Architect a schedule of values allocated to the various portions of the Work, prepared in such form and supported by such data to substantiate its accuracy as the Architect may require. This schedule, unless objected to by the Architect, shall be used only as a basis for the Contractor's Applications for Payment.

#### 9.3 APPLICATIONS FOR PAYMENT

9.3.1 At least ten days before the date for each progress payment established in the Owner-Contractor Agreement, the Contractor shall submit to the Architect an itemized Application for Payment, notarized if required, supported

by such data substantiating the Contractor's right to payment as the Owner or the Architect may require, and reflecting retainage, if any, as provided elsewhere in the Contract Documents.

9.3.2 Unless otherwise provided in the Contract Documents, payments will be made on account of materials or equipment not incorporated in the Work but delivered and suitably stored at the site and, if approved in advance by the Owner, payments may similarly be made for materials or equipment suitably stored at some other location agreed upon in writing. Payments for materials or equipment stored on or off the site shall be conditioned upon submission by the Contractor of bills of sale or such other procedures satisfactory to the Owner to establish the Owner's title to such materials or equipment or otherwise protect the Owner's interest, including applicable insurance and transportation to the site for those materials and equipment stored off the site.

9.3.3 The Contractor warrants that title to all Work, materials and equipment covered by an Application for Payment will pass to the Owner either by incorporation in the construction or upon the receipt of payment by the Contractor, whichever occurs first, free and clear of all liens, claims, security interests or encumbrances, hereinafter referred to in this Article 9 as "liens"; and that no Work, materials or equipment covered by an Application for Payment will have been acquired by the Contractor, or by any other person performing Work at the site or furnishing materials and equipment for the Project, subject to an agreement under which an interest therein or an encumbrance thereon is retained by the seller or otherwise imposed by the Contractor or such other person.

#### 9.4 CERTIFICATES FOR PAYMENT

9.4.1 The Architect will, within seven days after the receipt of the Contractor's Application for Payment, either issue a Certificate for Payment to the Owner, with a copy to the Contractor, for such amount as the Architect determines is properly due, or notify the Contractor in writing his reasons for withholding a Certificate as provided in Subparagraph 9.6.1.

9.4.2 The issuance of a Certificate for Payment will constitute a representation by the Architect to the Owner, based on his observations at the site as provided in Subparagraph 2.2.3 and the data comprising the Application for Payment, that the Work has progressed to the point indicated; that, to the best of his knowledge, information and belief, the quality of the Work is in accordance with the Contract Documents (subject to an evaluation of the Work for conformance with the Contract Documents upon Substantial Completion, to the results of any subsequent tests required by or performed under the Contract Documents, to minor deviations from the Contract Documents correctable prior to completion, and to any specific qualifications stated in his Certificate); and that the Contractor is entitled to payment in the amount certified. However, by issuing a Certificate for Payment, the Architect shall not thereby be deemed to represent that he has made exhaustive or continuous on-site inspections to check the quality or quantity of the Work or that he has reviewed the construction means, methods, techniques,

sequences or procedures, or that he has made any examination to ascertain how or for what purpose the Contractor has used the moneys previously paid on account of the Contract Sum.

#### 9.5 PROGRESS PAYMENTS

9.5.1 After the Architect has issued a Certificate for Payment, the Owner shall make payment in the manner and within the time provided in the Contract Documents.

9.5.2 The Contractor shall promptly pay each Subcontractor, upon receipt of payment from the Owner, out of the amount paid to the Contractor on account of such Subcontractor's Work, the amount to which said Subcontractor is entitled, reflecting the percentage actually retained, if any, from payments to the Contractor on account of such Subcontractor's Work. The Contractor shall, by an appropriate agreement with each Subcontractor, require each Subcontractor to make payments to his Subcontractors in similar manner.

9.5.3 The Architect may, on request and at his discretion, furnish to any Subcontractor, if practicable, information regarding the percentages of completion or the amounts applied for by the Contractor and the action taken thereon by the Architect on account of Work done by such Subcontractor.

9.5.4 Neither the Owner nor the Architect shall have any obligation to pay or to see to the payment of any moneys to any Subcontractor except as may otherwise be required by law.

9.5.5 No Certificate for a progress payment, nor any progress payment, nor any partial or entire use or occupancy of the Project by the Owner, shall constitute an acceptance of any Work not in accordance with the Contract Documents.

#### 9.6 PAYMENTS WITHHELD

9.6.1 The Architect may decline to certify payment and may withhold his Certificate in whole or in part, to the extent necessary reasonably to protect the Owner, if in his opinion he is unable to make representations to the Owner as provided in Subparagraph 9.4.2. If the Architect is unable to make representations to the Owner as provided in Subparagraph 9.4.2 and to certify payment in the amount of the Application, he will notify the Contractor as provided in Subparagraph 9.4.1. If the Contractor and the Architect cannot agree on a revised amount, the Architect will promptly issue a Certificate for Payment for the amount for which he is able to make such representations to the Owner. The Architect may also decline to certify payment or, because of subsequently discovered evidence or subsequent observations, he may nullify the whole or any part of any Certificate for Payment previously issued, to such extent as may be necessary in his opinion to protect the Owner from loss because of:

- .1 defective work not remedied,
- .2 third party claims filed or reasonable evidence indicating probable filing of such claims,
- .3 failure of the Contractor to make payments properly to Subcontractors or for labor, materials or equipment,

- .4 reasonable evidence that the Work cannot be completed for the unpaid balance of the Contract Sum,
- .5 damage to the Owner or another contractor,
- .6 reasonable evidence that the Work will not be completed within the Contract Time, or
- .7 persistent failure to carry out the Work in accordance with the Contract Documents.

9.6.2 When the above grounds in Subparagraph 9.6.1 are removed, payment shall be made for amounts withheld because of them.

#### 9.7 FAILURE OF PAYMENT

9.7.1 If the Architect does not issue a Certificate for Payment, through no fault of the Contractor, within seven days after receipt of the Contractor's Application for Payment, or if the Owner does not pay the Contractor within seven days after the date established in the Contract Documents any amount certified by the Architect or awarded by arbitration, then the Contractor may, upon seven additional days' written notice to the Owner and the Architect, stop the Work until payment of the amount owing has been received. The Contract Sum shall be increased by the amount of the Contractor's reasonable costs of shut-down, delay and start-up, which shall be effected by appropriate Change Order in accordance with Paragraph 12.3.

#### 9.8 SUBSTANTIAL COMPLETION

9.8.1 When the Contractor considers that the Work, or a designated portion thereof which is acceptable to the Owner, is substantially complete as defined in Subparagraph 8.1.3, the Contractor shall prepare for submission to the Architect a list of items to be completed or corrected. The failure to include any items on such list does not alter the responsibility of the Contractor to complete all Work in accordance with the Contract Documents. When the Architect on the basis of an inspection determines that the Work or designated portion thereof is substantially complete, he will then prepare a Certificate of Substantial Completion which shall establish the Date of Substantial Completion, shall state the responsibilities of the Owner and the Contractor for security, maintenance, heat, utilities, damage to the Work, and insurance, and shall fix the time within which the Contractor shall complete the items listed therein. Warranties required by the Contract Documents shall commence on the Date of Substantial Completion of the Work or designated portion thereof unless otherwise provided in the Certificate of Substantial Completion. The Certificate of Substantial Completion shall be submitted to the Owner and the Contractor for their written acceptance of the responsibilities assigned to them in such Certificate.

9.8.2 Upon Substantial Completion of the Work or designated portion thereof and upon application by the Contractor and certification by the Architect, the Owner shall make payment, reflecting adjustment in retainage, if any, for such Work or portion thereof, as provided in the Contract Documents.

#### 9.9 FINAL COMPLETION AND FINAL PAYMENT

9.9.1 Upon receipt of written notice that the Work is ready for final inspection and acceptance and upon receipt of a final Application for Payment, the Architect will

promptly make such inspection and, when he finds the Work acceptable under the Contract Documents and the Contract fully performed, he will promptly issue a final Certificate for Payment stating that to the best of his knowledge, information and belief, and on the basis of his observations and inspections, the Work has been completed in accordance with the terms and conditions of the Contract Documents and that the entire balance found to be due the Contractor, and noted in said final Certificate, is due and payable. The Architect's final Certificate for Payment will constitute a further representation that the conditions precedent to the Contractor's being entitled to final payment as set forth in Subparagraph 9.9.2 have been fulfilled.

9.9.2 Neither the final payment nor the remaining retained percentage shall become due until the Contractor submits to the Architect (1) an affidavit that all payrolls, bills for materials and equipment, and other indebtedness connected with the Work for which the Owner or his property might in any way be responsible, have been paid or otherwise satisfied, (2) consent of surety, if any, to final payment and (3), if required by the Owner, other data establishing payment or satisfaction of all such obligations, such as receipts, releases and waivers of liens arising out of the Contract, to the extent and in such form as may be designated by the Owner. If any Subcontractor refuses to furnish a release or waiver required by the Owner, the Contractor may furnish a bond satisfactory to the Owner to indemnify him against any such lien. If any such lien remains unsatisfied after all payments are made, the Contractor shall refund to the Owner all moneys that the latter may be compelled to pay in discharging such lien, including all costs and reasonable attorneys' fees.

9.9.3 If, after Substantial Completion of the Work, final completion thereof is materially delayed through no fault of the Contractor or by the issuance of Change Orders affecting final completion, and the Architect so confirms, the Owner shall, upon application by the Contractor and certification by the Architect, and without terminating the Contract, make payment of the balance due for that portion of the Work fully completed and accepted. If the remaining balance for Work not fully completed or corrected is less than the retainage stipulated in the Contract Documents, and if bonds have been furnished as provided in Paragraph 7.5, the written consent of the surety to the payment of the balance due for that portion of the Work fully completed and accepted shall be submitted by the Contractor to the Architect prior to certification of such payment. Such payment shall be made under the terms and conditions governing final payment, except that it shall not constitute a waiver of claims.

9.9.4 The making of final payment shall constitute a waiver of all claims by the Owner except those arising from:

- .1 unsettled liens,
- .2 faulty or defective Work appearing after Substantial Completion,
- .3 failure of the Work to comply with the requirements of the Contract Documents, or
- .4 terms of any special warranties required by the Contract Documents.

9.9.5 The acceptance of final payment shall constitute a waiver of all claims by the Contractor except those previously made in writing and identified by the Contractor as unsettled at the time of the final Application for Payment.

## ARTICLE 10

### PROTECTION OF PERSONS AND PROPERTY

#### 10.1 SAFETY PRECAUTIONS AND PROGRAMS

10.1.1 The Contractor shall be responsible for initiating, maintaining and supervising all safety precautions and programs in connection with the Work.

#### 10.2 SAFETY OF PERSONS AND PROPERTY

10.2.1 The Contractor shall take all reasonable precautions for the safety of, and shall provide all reasonable protection to prevent damage, injury or loss to:

- .1 all employees on the Work and all other persons who may be affected thereby;
- .2 all the Work and all materials and equipment to be incorporated therein, whether in storage on or off the site, under the care, custody or control of the Contractor or any of his Subcontractors or Sub-subcontractors; and
- .3 other property at the site or adjacent thereto, including trees, shrubs, lawns, walks, pavements, roadways, structures and utilities not designated for removal, relocation or replacement in the course of construction.

10.2.2 The Contractor shall give all notices and comply with all applicable laws, ordinances, rules, regulations and lawful orders of any public authority bearing on the safety of persons or property or their protection from damage, injury or loss.

10.2.3 The Contractor shall erect and maintain, as required by existing conditions and progress of the Work, all reasonable safeguards for safety and protection, including posting danger signs and other warnings against hazards, promulgating safety regulations and notifying owners and users of adjacent utilities.

10.2.4 When the use or storage of explosives or other hazardous materials or equipment is necessary for the execution of the Work, the Contractor shall exercise the utmost care and shall carry on such activities under the supervision of properly qualified personnel.

10.2.5 The Contractor shall promptly remedy all damage or loss (other than damage or loss insured under Paragraph 11.3) to any property referred to in Clauses 10.2.1.2 and 10.2.1.3 caused in whole or in part by the Contractor, any Subcontractor, any Sub-subcontractor, or anyone directly or indirectly employed by any of them, or by anyone for whose acts any of them may be liable and for which the Contractor is responsible under Clauses 10.2.1.2 and 10.2.1.3, except damage or loss attributable to the acts or omissions of the Owner or Architect or anyone directly or indirectly employed by either of them, or by anyone for whose acts either of them may be liable, and not attributable to the fault or negligence of the Contractor. The foregoing obligations of the Contractor are in addition to his obligations under Paragraph 4.18.



10.2.6 The Contractor shall designate a responsible member of his organization at the site whose duty shall be the prevention of accidents. This person shall be the Contractor's superintendent unless otherwise designated by the Contractor in writing to the Owner and the Architect.

10.2.7 The Contractor shall not load or permit any part of the Work to be loaded so as to endanger its safety.

### 10.3 EMERGENCIES

10.3.1 In any emergency affecting the safety of persons or property, the Contractor shall act, at his discretion, to prevent threatened damage, injury or loss. Any additional compensation or extension of time claimed by the Contractor on account of emergency work shall be determined as provided in Article 12 for Changes in the Work.

## ARTICLE 11

### INSURANCE

#### 11.1 CONTRACTOR'S LIABILITY INSURANCE

11.1.1 The Contractor shall purchase and maintain such insurance as will protect him from claims set forth below which may arise out of or result from the Contractor's operations under the Contract, whether such operations be by himself or by any Subcontractor or by anyone directly or indirectly employed by any of them, or by anyone for whose acts any of them may be liable:

1. claims under workers' or workmen's compensation, disability benefit and other similar employee benefit acts;
2. claims for damages because of bodily injury, occupational sickness or disease, or death of his employees;
3. claims for damages because of bodily injury, sickness or disease, or death of any person other than his employees;
4. claims for damages insured by usual personal injury liability coverage which are sustained (1) by any person as a result of an offense directly or indirectly related to the employment of such person by the Contractor, or (2) by any other person;
5. claims for damages, other than to the Work itself, because of injury to or destruction of tangible property, including loss of use resulting therefrom; and
6. claims for damages because of bodily injury or death of any person or property damage arising out of the ownership, maintenance or use of any motor vehicle.

11.1.2 The insurance required by Subparagraph 11.1.1 shall be written for not less than any limits of liability specified in the Contract Documents, or required by law, whichever is greater.

11.1.3 The insurance required by Subparagraph 11.1.1 shall include contractual liability insurance applicable to the Contractor's obligations under Paragraph 4.18.

11.1.4 Certificates of Insurance acceptable to the Owner shall be filed with the Owner prior to commencement of the Work. These Certificates shall contain a provision that

coverages afforded under the policies will not be cancelled until at least thirty days' prior written notice has been given to the Owner.

#### 11.2 OWNER'S LIABILITY INSURANCE

11.2.1 The Owner shall be responsible for purchasing and maintaining his own liability insurance and, at his option, may purchase and maintain such insurance as will protect him against claims which may arise from operations under the Contract.

#### 11.3 PROPERTY INSURANCE

11.3.1 Unless otherwise provided, the Owner shall purchase and maintain property insurance upon the entire Work at the site to the full insurable value thereof. This insurance shall include the interests of the Owner, the Contractor, Subcontractors and Sub-subcontractors in the Work and shall insure against the perils of fire and extended coverage and shall include "all risk" insurance for physical loss or damage including, without duplication of coverage, theft, vandalism and malicious mischief. If the Owner does not intend to purchase such insurance for the full insurable value of the entire Work, he shall inform the Contractor in writing prior to commencement of the Work. The Contractor may then effect insurance which will protect the interests of himself, his Subcontractors and the Sub-subcontractors in the Work, and by appropriate Change Order the cost thereof shall be charged to the Owner. If the Contractor is damaged by failure of the Owner to purchase or maintain such insurance and to so notify the Contractor, then the Owner shall bear all reasonable costs properly attributable thereto. If not covered under the all risk insurance or otherwise provided in the Contract Documents, the Contractor shall effect and maintain similar property insurance on portions of the Work stored off the site or in transit when such portions of the Work are to be included in an Application for Payment under Subparagraph 9.3.2.

11.3.2 The Owner shall purchase and maintain such boiler and machinery insurance as may be required by the Contract Documents or by law. This insurance shall include the interests of the Owner, the Contractor, Subcontractors and Sub-subcontractors in the Work.

11.3.3 Any loss insured under Subparagraph 11.3.1 is to be adjusted with the Owner and made payable to the Owner as trustee for the insureds, as their interests may appear, subject to the requirements of any applicable mortgagee clause and of Subparagraph 11.3.8. The Contractor shall pay each Subcontractor a just share of any insurance moneys received by the Contractor, and by appropriate agreement, written where legally required for validity, shall require each Subcontractor to make payments to his Sub-subcontractors in similar manner.

11.3.4 The Owner shall file a copy of all policies with the Contractor before an exposure to loss may occur.

11.3.5 If the Contractor requests in writing that insurance for risks other than those described in Subparagraphs 11.3.1 and 11.3.2 or other special hazards be included in the property insurance policy, the Owner shall, if possible, include such insurance, and the cost thereof shall be charged to the Contractor by appropriate Change Order.

11.3.6 The Owner and Contractor waive all rights against (1) each other and the Subcontractors, Sub-subcontractors, agents and employees each of the other, and (2) the Architect and separate contractors, if any, and their subcontractors, sub-subcontractors, agents and employees, for damages caused by fire or other perils to the extent covered by insurance obtained pursuant to this Paragraph 11.3 or any other property insurance applicable to the Work, except such rights as they may have to the proceeds of such insurance held by the Owner as trustee. The foregoing waiver afforded the Architect, his agents and employees shall not extend to the liability imposed by Subparagraph 4.18.3. The Owner or the Contractor, as appropriate, shall require of the Architect, separate contractors, Subcontractors and Sub-subcontractors by appropriate agreements, written where legally required for validity, similar waivers each in favor of all other parties enumerated in this Subparagraph 11.3.6.

11.3.7 If required in writing by any party in interest, the Owner as trustee shall, upon the occurrence of an insured loss, give bond for the proper performance of his duties. He shall deposit in a separate account any money so received, and he shall distribute it in accordance with such agreement as the parties in interest may reach, or in accordance with an award by arbitration in which case the procedure shall be as provided in Paragraph 7.9. If after such loss no other special agreement is made, replacement of damaged work shall be covered by an appropriate Change Order.

11.3.8 The Owner as trustee shall have power to adjust and settle any loss with the insurers unless one of the parties in interest shall object in writing within five days after the occurrence of loss to the Owner's exercise of this power, and if such objection be made, arbitrators shall be chosen as provided in Paragraph 7.9. The Owner as trustee shall, in that case, make settlement with the insurers in accordance with the directions of such arbitrators. If distribution of the insurance proceeds by arbitration is required, the arbitrators will direct such distribution.

11.3.9 If the Owner finds it necessary to occupy or use a portion or portions of the Work prior to Substantial Completion thereof, such occupancy or use shall not commence prior to a time mutually agreed to by the Owner and Contractor and to which the insurance company or companies providing the property insurance have consented by endorsement to the policy or policies. This insurance shall not be cancelled or lapsed on account of such partial occupancy or use. Consent of the Contractor and of the insurance company or companies to such occupancy or use shall not be unreasonably withheld.

#### 11.4 LOSS OF USE INSURANCE

11.4.1 The Owner, at his option, may purchase and maintain such insurance as will insure him against loss of use of his property due to fire or other hazards, however caused. The Owner waives all rights of action against the Contractor for loss of use of his property, including consequential losses due to fire or other hazards however caused, to the extent covered by insurance under this Paragraph 11.4.

## ARTICLE 12

### CHANGES IN THE WORK

#### 12.1 CHANGE ORDERS

12.1.1 A Change Order is a written order to the Contractor signed by the Owner and the Architect, issued after execution of the Contract, authorizing a change in the Work or an adjustment in the Contract Sum or the Contract Time. The Contract Sum and the Contract Time may be changed only by Change Order. A Change Order signed by the Contractor indicates his agreement therewith, including the adjustment in the Contract Sum or the Contract Time.

12.1.2 The Owner, without invalidating the Contract, may order changes in the Work within the general scope of the Contract consisting of additions, deletions or other revisions, the Contract Sum and the Contract Time being adjusted accordingly. All such changes in the Work shall be authorized by Change Order, and shall be performed under the applicable conditions of the Contract Documents.

12.1.3 The cost or credit to the Owner resulting from a change in the Work shall be determined in one or more of the following ways:

- .1 by mutual acceptance of a lump sum properly itemized and supported by sufficient substantiating data to permit evaluation;
- .2 by unit prices stated in the Contract Documents or subsequently agreed upon;
- .3 by cost to be determined in a manner agreed upon by the parties and a mutually acceptable fixed or percentage fee; or
- .4 by the method provided in Subparagraph 12.1.4.

12.1.4 If none of the methods set forth in Clauses 12.1.3.1, 12.1.3.2 or 12.1.3.3 is agreed upon, the Contractor, provided he receives a written order signed by the Owner, shall promptly proceed with the Work involved. The cost of such Work shall then be determined by the Architect on the basis of the reasonable expenditures and savings of those performing the Work attributable to the change, including, in the case of an increase in the Contract Sum, a reasonable allowance for overhead and profit. In such case, and also under Clauses 12.1.3.3 and 12.1.3.4 above, the Contractor shall keep and present, in such form as the Architect may prescribe, an itemized accounting together with appropriate supporting data for inclusion in a Change Order. Unless otherwise provided in the Contract Documents, cost shall be limited to the following: cost of materials, including sales tax and cost of delivery; cost of labor, including social security, old age and unemployment insurance, and fringe benefits required by agreement or custom; workers' or workmen's compensation insurance; bond premiums; rental value of equipment and machinery; and the additional costs of supervision and field office personnel directly attributable to the change. Pending final determination of cost to the Owner, payments on account shall be made on the Architect's Certificate for Payment. The amount of credit to be allowed by the Contractor to the Owner for any deletion

or change which results in a net decrease in the Contract Sum will be the amount of the actual net cost as confirmed by the Architect. When both additions and credits covering related Work or substitutions are involved in any one change, the allowance for overhead and profit shall be figured on the basis of the net increase, if any, with respect to that change.

**12.1.5** If unit prices are stated in the Contract Documents or subsequently agreed upon, and if the quantities originally contemplated are so changed in a proposed Change Order that application of the agreed unit prices to the quantities of Work proposed will cause substantial inequity to the Owner or the Contractor, the applicable unit prices shall be equitably adjusted.

## **12.2 CONCEALED CONDITIONS**

**12.2.1** Should concealed conditions encountered in the performance of the Work below the surface of the ground or should concealed or unknown conditions in an existing structure be at variance with the conditions indicated by the Contract Documents, or should unknown physical conditions below the surface of the ground or should concealed or unknown conditions in an existing structure of an unusual nature, differing materially from those ordinarily encountered and generally recognized as inherent in work of the character provided for in this Contract, be encountered, the Contract Sum shall be equitably adjusted by Change Order upon claim by either party made within twenty days after the first observance of the conditions.

## **12.3 CLAIMS FOR ADDITIONAL COST**

**12.3.1** If the Contractor wishes to make a claim for an increase in the Contract Sum, he shall give the Architect written notice thereof within twenty days after the occurrence of the event giving rise to such claim. This notice shall be given by the Contractor before proceeding to execute the Work, except in an emergency endangering life or property in which case the Contractor shall proceed in accordance with Paragraph 10.3. No such claim shall be valid unless so made. If the Owner and the Contractor cannot agree on the amount of the adjustment in the Contract Sum, it shall be determined by the Architect. Any change in the Contract Sum resulting from such claim shall be authorized by Change Order.

**12.3.2** If the Contractor claims that additional cost is involved because of, but not limited to, (1) any written interpretation pursuant to Subparagraph 2.2.8, (2) any order by the Owner to stop the Work pursuant to Paragraph 3.3 where the Contractor was not at fault, (3) any written order for a minor change in the Work issued pursuant to Paragraph 12.4, or (4) failure of payment by the Owner pursuant to Paragraph 9.7, the Contractor shall make such claim as provided in Subparagraph 12.3.1.

## **12.4 MINOR CHANGES IN THE WORK**

**12.4.1** The Architect will have authority to order minor changes in the Work not involving an adjustment in the Contract Sum or an extension of the Contract Time and not inconsistent with the intent of the Contract Documents. Such changes shall be effected by written order, and shall be binding on the Owner and the Contractor.

The Contractor shall carry out such written orders promptly.

## **ARTICLE 13**

### **UNCOVERING AND CORRECTION OF WORK**

#### **13.1 UNCOVERING OF WORK**

**13.1.1** If any portion of the Work should be covered contrary to the request of the Architect or to requirements specifically expressed in the Contract Documents, it must, if required in writing by the Architect, be uncovered for his observation and shall be replaced at the Contractor's expense.

**13.1.2** If any other portion of the Work has been covered which the Architect has not specifically requested to observe prior to being covered, the Architect may request to see such Work and it shall be uncovered by the Contractor. If such Work be found in accordance with the Contract Documents, the cost of uncovering and replacement shall, by appropriate Change Order, be charged to the Owner. If such Work be found not in accordance with the Contract Documents, the Contractor shall pay such costs unless it be found that this condition was caused by the Owner or a separate contractor as provided in Article 6, in which event the Owner shall be responsible for the payment of such costs.

#### **13.2 CORRECTION OF WORK**

**13.2.1** The Contractor shall promptly correct all Work rejected by the Architect as defective or as failing to conform to the Contract Documents whether observed before or after Substantial Completion and whether or not fabricated, installed or completed. The Contractor shall bear all costs of correcting such rejected Work, including compensation for the Architect's additional services made necessary thereby.

**13.2.2** If, within one year after the Date of Substantial Completion of the Work or designated portion thereof or within one year after acceptance by the Owner of designated equipment or within such longer period of time as may be prescribed by law or by the terms of any applicable special warranty required by the Contract Documents, any of the Work is found to be defective or not in accordance with the Contract Documents, the Contractor shall correct it promptly after receipt of a written notice from the Owner to do so unless the Owner has previously given the Contractor a written acceptance of such condition. This obligation shall survive termination of the Contract. The Owner shall give such notice promptly after discovery of the condition.

**13.2.3** The Contractor shall remove from the site all portions of the Work which are defective or non-conforming and which have not been corrected under Subparagraphs 4.5.1, 13.2.1 and 13.2.2, unless removal is waived by the Owner.

**13.2.4** If the Contractor fails to correct defective or non-conforming Work as provided in Subparagraphs 4.5.1, 13.2.1 and 13.2.2, the Owner may correct it in accordance with Paragraph 3.4.

13.2.5 If the Contractor does not proceed with the correction of such defective or non-conforming Work within a reasonable time fixed by written notice from the Architect, the Owner may remove it and may store the materials or equipment at the expense of the Contractor. If the Contractor does not pay the cost of such removal and storage within ten days thereafter, the Owner may upon ten additional days' written notice sell such Work at auction or at private sale and shall account for the net proceeds thereof, after deducting all the costs that should have been borne by the Contractor, including compensation for the Architect's additional services made necessary thereby. If such proceeds of sale do not cover all costs which the Contractor should have borne, the difference shall be charged to the Contractor and an appropriate Change Order shall be issued. If the payments then or thereafter due the Contractor are not sufficient to cover such amount, the Contractor shall pay the difference to the Owner.

13.2.6 The Contractor shall bear the cost of making good all work of the Owner or separate contractors destroyed or damaged by such correction or removal.

13.2.7 Nothing contained in this Paragraph 13.2 shall be construed to establish a period of limitation with respect to any other obligation which the Contractor might have under the Contract Documents, including Paragraph 4.5 hereof. The establishment of the time period of one year after the Date of Substantial Completion or such longer period of time as may be prescribed by law or by the terms of any warranty required by the Contract Documents relates only to the specific obligation of the Contractor to correct the Work, and has no relationship to the time within which his obligation to comply with the Contract Documents may be sought to be enforced, nor to the time within which proceedings may be commenced to establish the Contractor's liability with respect to his obligations other than specifically to correct the Work.

### 13.3 ACCEPTANCE OF DEFECTIVE OR NON-CONFORMING WORK

13.3.1 If the Owner prefers to accept defective or non-conforming Work, he may do so instead of requiring its removal and correction, in which case a Change Order will be issued to reflect a reduction in the Contract Sum where appropriate and equitable. Such adjustment shall be effected whether or not final payment has been made.

## ARTICLE 14

### TERMINATION OF THE CONTRACT

#### 14.1 TERMINATION BY THE CONTRACTOR

14.1.1 If the Work is stopped for a period of thirty days under an order of any court or other public authority

having jurisdiction, or as a result of an act of government, such as a declaration of a national emergency making materials unavailable, through no act or fault of the Contractor or a Subcontractor or their agents or employees or any other persons performing any of the Work under a contract with the Contractor, or if the Work should be stopped for a period of thirty days by the Contractor because the Architect has not issued a Certificate for Payment as provided in Paragraph 9.7 or because the Owner has not made payment thereon as provided in Paragraph 9.7, then the Contractor may, upon seven additional days' written notice to the Owner and the Architect, terminate the Contract and recover from the Owner payment for all Work executed and for any proven loss sustained upon any materials, equipment, tools, construction equipment and machinery, including reasonable profit and damages.

#### 14.2 TERMINATION BY THE OWNER

14.2.1 If the Contractor is adjudged a bankrupt, or if he makes a general assignment for the benefit of his creditors, or if a receiver is appointed on account of his insolvency, or if he persistently or repeatedly refuses or fails, except in cases for which extension of time is provided, to supply enough properly skilled workmen or proper materials, or if he fails to make prompt payment to Subcontractors or for materials or labor, or persistently disregards laws, ordinances, rules, regulations or orders of any public authority having jurisdiction, or otherwise is guilty of a substantial violation of a provision of the Contract Documents, then the Owner, upon certification by the Architect that sufficient cause exists to justify such action, may, without prejudice to any right or remedy and after giving the Contractor and his surety, if any, seven days' written notice, terminate the employment of the Contractor and take possession of the site and of all materials, equipment, tools, construction equipment and machinery thereon owned by the Contractor and may finish the Work by whatever method he may deem expedient. In such case the Contractor shall not be entitled to receive any further payment until the Work is finished.

14.2.2 If the unpaid balance of the Contract Sum exceeds the costs of finishing the Work, including compensation for the Architect's additional services made necessary thereby, such excess shall be paid to the Contractor. If such costs exceed the unpaid balance, the Contractor shall pay the difference to the Owner. The amount to be paid to the Contractor or to the Owner, as the case may be, shall be certified by the Architect, upon application, in the manner provided in Paragraph 9.4, and this obligation for payment shall survive the termination of the Contract.

1. The "General Conditions of the Contract for Construction," AIA Document A-201, Thirteenth Edition, August 1976, Articles 1 through 14 inclusive, is a part of this Contract.

2. The following supplements shall modify, delete and/or add to the General Conditions. Where any article, paragraph, or subparagraph in the General Conditions is supplemented by one of the following paragraphs, the provisions of such article, paragraph, or subparagraph shall remain in effect and the supplemental provisions shall be considered as added thereto. Where any article, paragraph, or subparagraph in the General Conditions is amended, voided, or superseded by any of the following paragraphs, the provisions of such article, paragraph, or subparagraph not so amended, voided, or superseded shall remain in effect.

3. Paragraph 1.2.3.: Add the following:

"In the event of conflict between the Specifications and the Drawings, the more stringent provision shall govern."

4. Paragraph 4.12.1.: Add the following:

"The Contractor shall prepare and submit all Shop Drawings, Samples, and other data in strict accordance with the provisions of the Specifications."

5. Paragraph 11.1.1.: In the first line, following the word "maintain," insert the following:

"...in a company or companies acceptable to the Owner."

6. Paragraph 11.1.2.: Delete in its entirety and substitute the following:

"The insurance required by subparagraph 11.1.1. shall be written for not less than any limits of Liability required by law or by those shown below and shall include Contractual Liability Insurance as applicable to the Contractor's obligations under paragraph 4.18.:

a. Workman's Compensation:	Statutory;
Employer's Liability:	Full statutory limits

b. Public Liability (per person/per occurrence):

1. Bodily and personal injury:	\$2,000,000/\$2,000,000;
--------------------------------	--------------------------

- 2. Property damage: \$2,000,000/\$2,000,000
- c. Automobile Liability (per person/per occurrence):
  - 1. Bodily injury: \$2,000,000/\$2,000,000;
  - 2. Property damage: \$2,000,000 per occurrence.
- d. Umbrella Liability  
(each occurrence/aggregate) \*/\*

\* Amount of Umbrella Liability Insurance shall be as required for Contractor to have a total of \$5,000,000.00 of Liability Insurance.

- e. The Owner and Designer shall be named as an additional Insured on the Certificate of Insurance and Contractor shall provide Owner a copy of the Endorsement. In addition, provide Waiver of Subrogation.
7. Paragraph 11.1.3.: Add the following:

"Certificates called for herein shall be furnished in triplicate and shall specifically set forth evidence of all coverage required by 11.1.1 and 11.1.2, and the Contractor shall furnish to the Designer copies of all endorsements that are subsequently issued amending coverage or limits."

8. Paragraph 11.3.1.: Delete in its entirety and substitute the following:

"The Contractor shall provide Builder's Risk Insurance in the amount of 100% of the Contract Sum protecting the Owner and holding the Owner harmless against claims which may arise from operations under this Contract."

9. Paragraph 11.3.6.: Add the following:

"In waiving rights of recovery under terms of this paragraph, the term 'Owner' shall be deemed to include his employees and the Designer and his employees as the Owner's Representatives, as provided for in these Contract Documents."

## 10. Stated Allowance:

The Contractor shall include the following cash allowances in his Proposal:

**\$20,000.00 for any unforeseen conditions.**

Paragraph 1.3.1. Copies furnished in ownership: Add the following:

"Designer will furnish free to the successful Contractor a maximum of three (3) sets of Contract Drawings and Specifications. Other necessary copies of Drawings, Specifications, and Details will be furnished to Contractor at cost of reproduction, but shall be returned as specified in 1.3.2."

Paragraph 4.3. Supervision and Construction Procedures: Add the following:

"Contractor shall coordinate work of various trades, Subcontractors and suppliers to expedite general progress of work. Scheduling and notices shall allow ample time for preparation, installation, and connection without delay or interference with other parts of work. The Designer will provide periodic inspection of the construction project to insure that the desired end result project will be achieved as conceived by the Designer and Owner. The Designer in no way purports to provide any supervision of work forces, or to perform safety inspections, or in any way direct the operations of the Contractor. The Designer shall not be liable for methods of construction utilized by the Contractor or any violations of OSHA or other regulations. The Contractor shall hold the Owner and Designer free from Liability due to construction procedures or negligence on the part of any of the Contractor's employees."

Paragraph 4.7. Permits, Fees, and Notices: Add the following:

"Contractor shall secure, pay for, and deliver to Owner all permits and certificates required by law and by the Specifications. Contractor shall verify grades, lines, levels, boundaries, and structured locations. He shall promptly report to the Designer any apparent errors or discrepancies before proceeding with work."

Contractor shall pay all fees associated with the construction of this project."

Paragraph 9.5.1. Payment withheld: To item 3., add the following:

"Contractor shall not withhold from the Subcontractor or suppliers more than percentage withheld from the certificate for their portion of work."

Paragraph 9.6.1.7: Add the following:

"Failure of Contractor to comply with requirements for maintaining proper record drawings specified."

Paragraph 9.3.1.: Add the following: "On or before the last day of each month during work progress, Contractor shall submit request for payment, itemized list of work, or parts of work completed, and of materials stored on site (or approved off-site location) on an approved form supplied by the Designer. On or before the seventh day of each month, Designer will issue certificate of payment for 95% of the amount of the Contractor's request for payment, provided that items listed are substantiated by physical conditions. Payments will be made by Owner to Contractor not later than 60 days following the end of the Period covered by the Application for Payment."

Paragraph 13.2.2.: "Contractor shall, in case of work performed by his Subcontractor and where guarantees are required, secure warranties from said Subcontractors upon the appropriate forms provided herein and deliver copies of same to the Designer upon completion of the work. The Contractor shall and hereby does warrant all work performed by him directly and for which guarantees are required in the Sections of these Specifications. The Contractor shall guarantee the Roofing System for a period of two (2) years, as set out on the guarantee form enclosed."

Article 8: Add the following at the end of Paragraph 8.2.2:

"Immediately after the award of the Contract, the General Contractor shall prepare a graphic critical path construction schedule indicating the date of starting of each phase of the work, the duration of each phase, and the date of completion of each phase of work as well as the entire Contract. The construction schedule shall be used, among other things, to determine that the Owner, Designer, and Contractor may have a means of judging the progress of the work, that each Subcontractor and material supplier may have a basis of scheduling his work, that the Designer may have a basis for scheduled checking of Shop Drawings and preparing any supplementary Details, and the Owner may have a basis for scheduling transportation and installation of manufacturing equipment, as well as financial arrangements."

Paragraph 4.3.1.: Add the following:

"The Contractor shall verify all grades, lines, levels and dimensions as shown on the Drawings and shall report any errors or inconsistencies in the above to the Designer before commencing work."



Add the following as Article 15:

The Parties mutually agree that all disputes under this Agreement will first be submitted to non-binding mediation in McMinnville, Tennessee. Each Party will pay one half of the mediation cost. If the dispute is not resolved, the Parties agree that the exclusive jurisdiction and venue to resolve the dispute will be the Chancery Court of Warren County, Tennessee.

Add the following to Article 4:

If Contractor uses a roofing subcontractor, Contractor shall have a superintendent on site at all times any work is being performed.

Add the following to Article 8:

Contractor shall provide all Close-Out Documents (Warranty, Release of Liens, Final Pay Request, O/M manuals, etc.) within 60 days of Substantial Completion, unless more days are shown on Certificate of Substantial Completion. If Contractor does not provide these Documents within 60 days of Substantial Completion, Liquidated Damages will be imposed at \$100.00 per Calendar Day until Documents have been provided.

END OF SECTION

## PART 1 - GENERAL

- A. SUBMITTALS REQUIRED: SHOP DRAWINGS( ); MATERIALS LIST( ); SAMPLES( ); MANUALS( ); CERTIFICATES(X); OTHER( )
- B. Contractor shall provide and pay for the following: all labor, equipment, tools, machinery and materials to complete the "**Roof Replacement – Middle School Auditorium,**" Warren County, Tennessee, Project as shown on the Drawings and/or described in all Sections of the Specifications and Contract Documents and as follows:
1. Provide and pay for the following items in amounts necessary to complete the work:
    - a. Workman's Compensation and Employer's Liability Insurance, Bodily Injury Liability and Property Damage Liability Insurance, Automobile Bodily Injury Liability, Property Damage Liability Insurance and Builder's Risk Insurance.
    - b. Performance and Payment Bonds covering all labor and materials in the full amount of the Contract Price.
    - c. Building Permit. All lawful fees, permits and licenses required by public utilities or authorities.
    - d. Contractor shall supply all necessary utilities essential to successful completion of the job. Contractor shall pay in full all costs of such utilities.
  2. Contractor shall make an examination of the site and take into consideration all such conditions that may affect the work.
  3. Verify all grades, lines, levels and dimensions shown on the Drawings, and report any error or inconsistencies to Designer prior to commencing work.
  4. General Protection Requirements:
    - a. Protect the building and grounds from water damage of any sort. Provide all pumps, equipment and enclosures to provide this protection and keep building free of water during the life of the Contract.

- b. Provide protection against wind, storms, cold or heat, so as to maintain all work, materials, and equipment free from injury or damage. At the end of the day's work, items likely to be damaged shall be covered.
  - c. Exercise utmost care to protect all existing utility lines from damage during construction. Determine whether or not such lines are still in service or have been abandoned. If abandoned, the lines shall be neatly cut off and permanently capped in a watertight manner. If still in service, lines shall be rerouted as necessary to keep them in service.
  - d. Provide and erect before any work begins, and maintain during the progress of the work, all necessary fences, walk ways, warning signals, signs and lights adjacent to public streets. Extent of the work and details of the construction shall be in strict accordance with the requirements of all local and/or state codes and/or regulations.
  - e. Keep the work clean and free from unsightly and dangerous accumulations of materials such as trash, etc. Store piles of materials as close to the construction as possible. Clean site of trash each day. Provide protection about dangerous openings of any sort to protect all persons from injury.
  - f. All work damaged by failure to provide required protection above shall be removed and replaced with new work of equal kind and quality at the Contractor's expense.
5. Furnish and maintain, or see that each Subcontractor furnishes and maintains, all equipment required for the proper execution of the work. All such apparatus and equipment shall meet all requirements of the Labor Law and other federal, state, or local laws applicable thereto.
  6. Check all dimensions and report any error or omission in the Drawings or Specifications to the Designer in writing.
  7. Work shall be commenced on a date to be specified in a written order by the Designer. This order will not be issued until the Contractor has delivered to the Owner, through the Designer, satisfactory proof of carriage of all insurance required herein, properly executed Performance Bond, and completed list of all Subcontractors, as approved by the Designer. The Designer shall retain the authority to approve or disapprove any Subcontractor.

8. Method of Award Involving Options: The Owner reserves the right to award the Bid to the lowest qualified responsible Bidder considering all, any of, or none of the Option and Alternate Bids requested, whichever may be in the best interest of the Owner.
9. Options and Alternate Bids are listed below:

**ADD ALTERNATE 1:** Provide and install a fully adhered, LSFR, non-reinforced, black, .090" EPDM membrane in lieu of .060" EPDM membrane. Provide 30-Year, NDL Roof Warranty with 72 mph wind speed, Accidental Puncture and 2" hail Warranty.
10. Meetings and Conferences: The Contractor and each of his Subcontractors shall meet with the Owner and the Designer as shall be deemed necessary to coordinate and expedite the project. The frequency of said meetings will vary with the complexity of the work and the rate of progress of the project. It is anticipated that in addition to the preconstruction conference, meetings will be held periodically throughout the implementation of the project up to and including the final inspection of the project.
11. Submittals and Substitutions: Wherever possible throughout the Contract Documents the minimum acceptable quality of workmanship and materials has been defined either by recognized standards, performance specification, or manufacturer's name and/or catalog number. To ensure that the specified products are furnished and installed in accordance with the intent of the design, procedures have been established for advanced submittal of design data and for their review and approval or rejection by the Designer. The specification of a Manufacturer's brand name in no way is intended to limit competition, nor should it be construed to indicate that no other product will be accepted by the Designer. The use of brand names and catalog numbers is merely intended to establish an industry standard. Unless specified otherwise, the Designer will review Submittals requesting changes from items which have been specified; provided, the Designer feels that the product requested to be used as a substitution for the product specified meets or exceeds all the standards expected by the Designer of that project. No substitution shall be permitted on the job without prior approval of the Designer of that substitution. All Submittals, including Shop Drawings, samples, manufacturer's literature, colors, and other data, shall be submitted to the Designer at the earliest possible date. Under no circumstances shall any product specified herein be ordered or installed without prior approval of the Designer where the Plans and/or Specifications indicate that prior approval is required.

## PART 2 - PRODUCTS

- A. Shop Drawings: Shop Drawings shall be drawn to scale and of sufficient detail to show all pertinent features of the item and its method of connection to the work. Submit electronic copy of Shop Drawings to the Designer (jason@rinks-consulting.com).
- B. Samples: Samples shall be supplied to Designer and shall be left in Designer's permanent file for the project. Unless otherwise specifically directed by the Designer, all samples shall be of the precise article proposed to be furnished. Should the Contractor desire a sample for his file, he should submit all samples in the quantity which is required to be returned, plus one which shall be retained by the Designer.
- C. Colors: Colors of various samples will be selected from the standard color choice or pattern which is available in the specified product. Either actual products or accurate color charts and pattern charts shall be submitted to the Designer for his review and selection.
- D. Substitutions: Should the Contractor desire to substitute an item for an item which has been specified, he shall demonstrate to the Designer's satisfaction that the substituted product is, in fact, equal to or better than the product specified. The Designer's decision in this matter will be final.

## PART 3 - EXECUTION

- A. All Submittals shall be identified by consecutive, chronological numbers being attached to each submittal. Each submittal shall have a letter of transmittal indicating the transmittal number, date of transmittal, and the item transmitted. Should an item need to be resubmitted, transmit under a new letter of transmittal with a new identification number; however, it should maintain a submittal log which accurately indicates all Submittals processed for this project. The Contractor shall coordinate all Submittals, including the following procedures:
  - 1. Determine and verify all field dimensions and conditions, catalog numbers, and similar data.
  - 2. Coordinate with all trades and all public agencies involved.
  - 3. Secure all necessary approvals from public agencies and others, signified by their stamps of approval.

4. Clearly indicate all deviations from Contract Documents.
- B. Timing of Submittals: Contractor shall make all submittals far enough in advance of scheduled dates for ordering and/or installation to provide required time for reviews and for securing necessary approvals, including time for possible revision and resubmittals. In scheduling this, the Contractor shall allow approximately eight working days for the Designer's review following his receipt of the submittal.
- C. The Contractor shall stockpile any and all items which are removed from this project which the Owner deems salvageable for the Owner to pick up. All items which the Owner deems unsalvageable shall be disposed of by the Contractor.
- D. Contractor employees shall minimize traffic inside the building. When in building, Contractor employees shall wear shoe covers to protect floor surfaces. Contractor shall provide employee toilet facilities so employees do not enter building to use toilets.
- E. Building must be occupied while roof replacement is in progress. Take all steps necessary to ensure the inside of the facility does not suffer dust, dirt, debris, or water damage. Tear off no more roof than can be replaced and properly flashed prior to the end of the work day. Ensure all overnight tie-ins are one hundred percent watertight.
- F. Provide Owner with the telephone number of a responsible Contractor representative the Owner can call 24-hours a day in the event of an emergency.
- G. Contractor shall keep an accurate set of As-Builts as the Project progresses. Contractor shall turn over As-Builts to Owner upon completion of the Project.
- H. All of the Contractor's employees shall conduct themselves in a responsible manner around Building Occupants. Employees shall be cordial, but not engage in conversation. Contractor's employees shall keep shirts on at all times.

END OF SECTION

1. **BASE BID (60 Consecutive Calendar Days):** Remove and properly dispose of all debris, adhered EPDM roof membrane, tapered EPS insulation and flashings to existing isocyanurate insulation. Back out and remove all insulation fasteners and plates. Inspect existing isocyanurate insulation with Delmhorst meter and replace all wet and/or damaged insulation. Remove and properly dispose of edge metal, metal coping, gutters, downspouts, conductor heads, metal fascia cover, faceplates and metal counterflashing at locations shown on the Plans. Provide and install new wood blocking at locations shown on the Plans. Treat any rusted metal deck with rust inhibitor and replace any metal and/or wood deck which will not achieve proper pull results. Remove and reinstall/replace existing insulation around perimeter and penetrations as required to install new EPDM air barrier and high-density foam. Mechanically attach new 1.5" isocyanurate, 1/8" per foot tapered isocyanurate and 1/4" per foot isocyanurate crickets using fastener pattern shown on the Plans. In foam adhesive, provide and install new 1/2" cover board to new isocyanurate insulation using foam pattern shown on the Plans. Provide and install new .060", FR, non-reinforced, black, fully adhered EPDM Roof System with a 20-Year, No Dollar Limit, Warranty with 72 mph wind speed and 2" diameter Hail Warranty. Provide and install new Kynar 500 edge metal, metal coping, gutters, downspouts, fascia cover, conductor heads and metal counterflashing. Provide and install new overflow scuppers and faceplates at location shown on the Plans. All metal work shall meet ES-1 attachment requirements. Contractor shall include in Base Bid a \$20,000.00 Allowance for unforeseen conditions.
2. **ADD ALTERNATE 1:** Provide and install a fully adhered, LSFR, non-reinforced, black, .090" EPDM membrane in lieu of .060" EPDM membrane. Provide 30-Year, NDL Warranty with 72 mph wind speed, Accidental Puncture and 2" hail Warranty.
3. Contractor may use facility electricity unless the privilege is abused, at which time the use will not be permitted and the Contractor will be required to obtain electricity elsewhere at no extra charge to the Owner.
4. Keep work area and grounds clean at all times and protect inside and outside of facility from damage. The facility must remain occupied and dry during the work. Contractor shall not interfere with Owner's normal day-to-day operations of the building. Contractor will be provided an area on-site for storage of materials, if so desired.

5. The Contractor shall conform to OSHA and other safety requirements during this operation. Keep all tools, equipment, materials and personnel (as practicable) away from roof perimeters to prevent damage or injury on the construction Site and to protect the structure and public below. Owner and Designer are not responsible for Contractor's safety.
6. No work is anticipated by others. No future work is anticipated.
7. Contractor's Use of Premises: Staging area will be provided, to be coordinated with building Owner.
8. Owner must continue to occupy building during the work of this Contract. Contractor shall keep building dry and free of debris at all times.
9. See Plans for more specific description of work items.
10. All of the Contractor's employees shall conduct themselves in a responsible manner around Building Occupants. Employees shall be cordial, but not engage in conversation. Contractor's employees shall keep shirts on at all times.

END OF SECTION



## PART 1 – GENERAL

## 1.01 EXTENSIONS OF CONTRACT TIME

- A. If the basis exists for an extension of time in accordance with paragraph 8.3 of the Conditions, an extension of time on the basis of weather may be granted only for the number of Weather Delay Days in excess of the number of days listed as the Standard Baseline for that month.

## 1.02 STANDARD BASELINE FOR AVERAGE CLIMATIC RANGE

- A. The Designer has reviewed weather data available from the National Oceanic and Atmospheric Administration and determined a Standard Baseline of average climatic range for the State of Tennessee.
- B. Standard Baseline shall be regarded as the normal and anticipatable number of calendar days for each month during which construction activity shall be expected to be prevented and suspended by cause of adverse weather. Suspension of construction activity for the number of days each month as listed in the Standard Baseline is include in the Work and is not eligible for extension of Contract Time.
- C. Standard Baseline is as follows:
- |     |     |     |     |     |     |     |     |     |     |     |     |
|-----|-----|-----|-----|-----|-----|-----|-----|-----|-----|-----|-----|
| Jan | Feb | Mar | Apr | May | Jun | Jul | Aug | Sep | Oct | Nov | Dec |
| 12  | 11  | 8   | 7   | 7   | 6   | 7   | 5   | 4   | 5   | 6   | 11  |

## 1.03 ADVERSE WEATHER and WEATHER DELAY DAYS

- A. Adverse Weather is defined as the occurrence of one or more of the following conditions which prevents exterior construction activity or access to the site within twenty-four (24) hours:
1. precipitation (rain, snow, or ice) in excess of one-tenth inch (0.10") liquid measure
  2. temperatures which do not rise above 32 degrees F by 10:00 a.m.
  3. temperatures which do not rise above that specified for the day's construction activity by 10:00 a.m., if any is specified
  4. sustained wind in excess of twenty-five (25) m.p.h.
  5. standing snow in excess of one inch (1.00").

6. days where there is a 30% or greater forecast for precipitation the day before and the Contractor does not work that day based upon the forecast.
- B. Adverse Weather may include, if appropriate, "dry-out" or "mud" days:
    1. for rain days above the standard baseline;
    2. only if there is a hindrance to site access or sitework, such as excavation, backfill, and footings; and,
    3. at a rate no greater than 1 make-up day for each day or consecutive days of rain beyond the standard baseline that total 1.0 inch or more, liquid measure, unless specifically recommended otherwise by the Designer.
  - C. A Weather Delay Day may be counted if adverse weather prevents work on the project for fifty percent (50%) or more of the contractor's scheduled work day, including a weekend day or holiday if Contractor has scheduled construction activity that day.

#### 1.04 DOCUMENTATION and SUBMITTALS

- A. Submit daily jobsite work logs showing which and to what extent construction activities have been affected by weather on a monthly basis.
- B. Submit actual weather data to support claim for time extension obtained from nearest NOAA weather station or other independently verified source approved by Designer at beginning of project. Use Standard Baseline data provided in this Section when documenting actual delays due to weather in excess of average climatic range.
- C. If adverse weather conditions are the basis for a Claim for additional time, such Claim shall be documented by data substantiating that weather conditions were abnormal for the period of time, could not have been reasonably anticipated and had an adverse effect on the scheduled construction. Organize Claim and documentation to facilitate evaluation on a basis of calendar month periods.
- D. If an extension of the Contract Time is appropriate, it shall be effected in accordance with the provisions of Article 8 of the Conditions, and the applicable General Requirements.

END OF SECTION

**PART 1 - GENERAL**

The site shall be kept clean daily. All torn-out material shall be removed without damaging property. All material torn out and not to be reused shall become the property of the Contractor and shall be immediately removed from the site. A final cleaning at the end of the project shall be performed to the satisfaction of the Owner.

Contractor shall pick up nails and debris daily or more often if required. Contractor will be responsible for any damage to tires from nails, screws or debris in parking lot.

Contractor shall install erosion control measures as required to keep the site and roads clean and to prevent silt runoff.

**PART 2 - PRODUCTS**

NONE

**PART 3 - EXECUTION**

NONE

END OF SECTION

## PART 1 - GENERAL

- A. SUBMITTALS REQUIRED: SHOP DRAWINGS(X); MATERIALS LIST(X); SAMPLES( ); MANUALS( ); CERTIFICATES( ); OTHER( )
- B. DESCRIPTION: Work included in this Section is as indicated on the Drawings. In general, the work of this Section includes replacement metal deck.
- C. QUALITY ASSURANCE: The steel fabricator shall have previous experience in fabrication of structural steel. The steel erector shall have previous experience in the erection of structural steel. All welding performed under this Section shall be done by properly-qualified welders in accordance with AWS Specifications, and the work of this Section shall conform with the appropriate codes and regulations including the specifications for design, fabrication and erection of structural steel for buildings by the American Institute of Steel Construction.
- D. PRODUCT HANDLING: All materials in this Section shall be protected during and after installation from other trades. In the event of damage, immediately make all repairs and replacements necessary to the approval of the Designer, at no additional cost to the Owner.

## PART 2 - PRODUCTS

- A. REPLACEMENT METAL DECK: Replacement metal deck shall be 1.5" matching 20 ga. and painted. Metal deck shall be screwed to bar joists on 12" C.C. in the field and 6" C.C. within 6' of the edge. Fasteners shall be #12 x 1.5" long self-drilling, hex washer.

## PART 3 - EXECUTION

- A. CLEAN-UP AND FIELD TOUCH-UP: Grind smooth and clean all exposed areas and touch-up all abrasions, scratches and defects incurred during installation. Leave all work in a first-class condition for other trades.

END OF SECTION

## PART 1 - GENERAL

- A. SUBMITTALS REQUIRED: SHOP DRAWINGS(X); MATERIALS LIST(X); SAMPLES( ); MANUALS( ); CERTIFICATES( ); OTHER( )
- B. SCOPE & QUALITY ASSURANCE: Furnish and install all Rough Carpentry as indicated on the Drawings. In addition to complying with all pertinent Codes and Regulations, (In the event of conflict between pertinent codes, regulations, referenced standards, or these Specifications, the more stringent shall govern.) all materials of this Section shall comply with pertinent provisions of:

No. 2 Southern Pine: Southern Pine Institute.

New Plywood shall be exterior grade "CD" plywood.

Provide skilled workmen and supervisors during execution of this work who are familiar with the type of construction involved and the materials and technique specified. In the acceptance or rejection of rough carpentry, no allowance will be made for lack of skill on the part of workmen.

- C. PRODUCT HANDLING:
1. Use all means necessary to protect materials and other work from damage, abuse, weather or people.
  2. In the event of damage, immediately make all repairs and replacements necessary to the approval of the Designer and at no additional cost to the Owner.

## PART 2 - PRODUCTS

- A. GRADE STAMPS: Identify all materials of this Section by the appropriate stamp of the agency listed in the reference standards, or by such other means as are approved in advance by the Designer.

- B. **MATERIALS:** All materials of this Section, unless specifically otherwise approved in advance by the Designer, shall meet or exceed the following:

All wood blocking shall be No. 2 Southern Pine (unless it comes into contact with existing lightweight insulating concrete). Wood shall not be treated with preservative solutions containing copper. If preservative treated wood is required, then all fasteners in the wood shall be stainless steel. Pressure treated wood blocking shall not come into contact with metal deck. If pressure treated wood blocking is used, a 30 lb. felt shall be used to separate the wood from the metal deck. All plywood shall be exterior grade "CD" plywood. Any new wood blocking that comes into contact with existing lightweight insulating concrete shall be pressure treated and shall be attached using stainless steel fasteners. All pressure treated wood blocking shall be separated from all other metals by roofing felt.

Any replacement wood decking shall be 3/4" Exterior Grade Plywood and shall be screwed to the structure on 6" centers.

### PART 3 - EXECUTION

#### A. SURFACE CONDITIONS:

1. Prior to all work of this Section, carefully inspect the installed work of all other trades and verify that all such work is complete to the point where this installation may properly commence. Verify that rough carpentry may be performed in strict accordance with the original design and all pertinent Codes and Regulations.
2. In the event of discrepancy, immediately notify the Designer. Do not proceed with installation in areas of discrepancy until all such discrepancies have been fully resolved.

- B. **WORKMANSHIP:** All rough carpentry shall produce joints true, tight, and well nailed, with all members assembled in accordance with the Drawings and with all pertinent Codes and Regulations. Carefully select all members; select individual pieces so that knots and obvious defects will not interfere with placing bolts or proper nailing or making proper connections. Cut out and discard all defects which will render a piece unable to serve its intended function; lumber may be rejected by the Designer, whether or not it has been installed, for excessive warp, twist, bow, crook, mildew, fungus, or mold, as well as for improper cutting and fitting.

**C. BLOCKING:**

Install all blocking required to support all items of finish as shown on the Plans.

**D. FASTENING:**

Bolting: Drill holes 1/16-inch larger in diameter than the bolts being used; drill straight and true from one side only. Bolt threads must not bear on wood; use washers under head and nut where both bear on wood; use washers under all nuts.

**E. BLOCKING:** Existing perimeter wood blocking in good condition may remain provided it meets the attachment requirements below.

All perimeter wood blocking shall be attached to the structure with bolts, screws or spikes as appropriate through all thicknesses of blocking to meet the attachment requirements below.

**ATTACHMENT REQUIREMENTS:**

- a. All existing and new wood blocking attachment shall be in accordance with ES-1 and FM 1-49 requirements and shall resist a minimum force of 200 pounds per linear foot in any direction.
- b. Do not countersink nuts/fastener heads lower than the top of the wood blocking being attached.
- c. The spacing of the fasteners may vary as required to achieve this standard. Spacing of fasteners at corners shall be cut in half. Dimensions of corners shall be per ES-1 and FM 1-49 requirements, but a minimum of 8'x8'.

**F. CLEANING UP:**

1. Keep the premises in a neat, safe, and orderly condition at all times during execution of this portion of the work, free from accumulation of sawdust, cut ends, and debris.
2. At the end of each working day, or more often if necessary, thoroughly sweep all surfaces where refuse from this portion of the work has settled. Remove the refuse to the area of the job site set aside for its storage. Upon completion of this portion of the work, thoroughly broom-clean all surfaces.

END OF SECTION

## PART 1 - GENERAL

- A. SUBMITTALS REQUIRED: SHOP DRAWINGS( ); MATERIALS LIST(X); SAMPLES(X); MANUALS( ); CERTIFICATES( ); OTHER( )
- B. Work included in this section consists of, but is not necessarily limited to, mechanical fasteners and foam adhesive used to secure new roof insulation.
- C. Deliver materials to the jobsite and store in a safe, dry place with labels intact and protect materials before, during and after installation. Replace all damaged materials at no additional cost to the Owner.

## PART 2 - PRODUCTS

- A. METAL DECK: Fasteners for metal decks shall be Elevate, Carlisle, Versico or Johns Manville Standard Roof Fastener specifically designed for metal decks. Shank diameter shall be .170 with a thread diameter of .215. The fastener must have 11 threads per inch and have a 30 degree spade point. The fastener shall be used with a 3" round pressure plate. Contractor shall use correct length of fastener as dictated by insulation thickness. Fasteners shall be approved by EPDM manufacturer and covered under EPDM Warranty.
- B. FOAM INSULATION ADHESIVE: Foam Insulation adhesive used to secure cover board to isocyanurate shall be Elevate I.S.O. Twin Pack, Carlisle Fast 100 dual cartridges, Johns Manville Two-Part Urethane Insulation adhesive (UIA) or Versico Fast 100-LV. All other low rise adhesive substitutions must have prior Designer's approval. **A continuous bead of adhesive shall be installed 2" from all edges of each insulation board in addition to Manufacturer's recommendations.** Foam insulation adhesive shall be approved by EPDM manufacturer and covered under EPDM Warranty. Foam insulation adhesive shall be installed in strict accordance with Manufacturer's recommendations (i.e. width of bead at application point, timing of insulation installed into adhesive, etc.).

## PART 3 - EXECUTION

- A. INSPECTION: Prior to the installation of the mechanical fasteners, insure that the area to receive the insulation and fasteners is completely free of all foreign debris and material. Apply the fasteners and foam in strict compliance with Manufacturer's recommendations.



- B. Upon the completion of the installation, leave the surface clean and free of debris. Immediately remove all excess debris which is a result of this work from the jobsite.
  
- C. Contractor shall inspect metal deck above ceilings to verify presence of any electrical conduit at or just below metal deck which could be penetrated by an insulation fastener. Contractor shall reflect any conduit to the roof to prevent electrical conduit from being penetrated. Insulation fastener location may be shifted as required, but number of fasteners shall not be changed. Contractor shall be responsible for repairing any damaged electrical conduit to its prior condition at no cost to the Owner.

END OF SECTION

## PART 1 - GENERAL

- A. SUBMITTALS REQUIRED: SHOP DRAWINGS(X); MATERIALS LIST(X); SAMPLES( ); MANUALS( ); CERTIFICATES( ); OTHER( )
- B. Work included in this Section includes, but is not necessarily limited to, roof insulation and tapered insulation as shown on Drawings.
- C. Deliver materials to the jobsite and store in a safe, dry place with labels intact and protect materials before, during and after installation. Replace all damaged materials at no additional cost to the Owner.

## PART 2 - PRODUCT

- A. New 1.5" isocyanurate insulation, 1.5" replacement isocyanurate insulation, 1/8" per foot tapered isocyanurate insulation and 1/4" per foot isocyanurate crickets shall be Resista Insulation by Elevate, SecurShield POLYISO by Carlisle, ENRGY 3 CGF by Johns Manville or Secureshield POLYISO by Versico for a Total System, 20 or 30-Year, No Dollar Limit Warranty.
- B. Tapered edge strips shall be isocyanurate insulation as manufactured by Elevate, Carlisle, Johns Manville or Versico.
- C. Batt insulation for expansion joints and other locations shall be R-19 Owen Corning un-faced insulation.
- D. New cover board shall be 1/2" Isogard HD by Elevate, 1/2" SecureShield HD by Carlisle, 1/2" Protector HD by Johns Manville or 1/2" SecureShield HD by Versico.

**See Drawings for insulation attachment in field, perimeter and corners.**

All insulation joints shall be staggered. All gaps in insulation over 1/4" shall be filled with similar insulation.

## PART 3 - EXECUTION

- A. Prior to the installation of the insulation, ensure the area to receive the insulation is completely free of all foreign debris and material. Apply the insulation in strict compliance with Manufacturer's recommendations.

- B. Upon the completion of the installation, leave the insulation surface clean and free of debris, ready to receive the roofing material. Immediately remove all excess debris which is a result of this work from the jobsite.
- C. **ANY INSULATION WHICH GETS WET SHALL BE REMOVED FROM THE JOBSITE AT NO COST TO THE OWNER, NO QUESTIONS ASKED!**
- D. Insulation shall leave the Manufacturer's Factory completely and adequately protected from the weather on the truck. Contractor shall furnish a copy of this Specification to the insulation Manufacturer when ordering insulation and request that no insulation be shipped with damaged weather protection, whatsoever.

Contractor shall provide Designer with digital pictures of all views/sides of every truck showing the protected insulation arriving on the jobsite. Insulation which arrives at the jobsite with the protection cut, ripped or damaged in any way which would permit moisture intrusion into the insulation in transit shall be REJECTED and sent back to the Manufacturer at no cost to the Owner. Notify the Designer immediately of all insulation which arrives at the jobsite with any damage to the insulation or protective wrapping.

Bundles of shrink wrapped or otherwise wrapped bundles of insulation shall be stored on wood 4x4's off the roof or ground at all times and must be covered with 6 mil poly and breathable tarps at all times when work is not ongoing. Tarps shall be secured with ropes which pass under, above and around all sides of the tarped insulation. All stacks of all insulation bundles shall have secure tarps protecting the top and all four sides of the insulation stack all the way to the ground or roof. The tarps must be adequately secured with ropes which prevent any edge of any tarp from blowing up in winds of 55 mph or less.

END OF SECTION

## PART 1 - GENERAL

- A. SUBMITTALS REQUIRED: SHOP DRAWINGS(X); MATERIALS LIST(X); SAMPLES( ); MANUALS( ); CERTIFICATES( ); OTHER( )
- B. DESCRIPTION: Work includes, but is not limited to: Remove and properly dispose of all debris, adhered EPDM roof membrane, tapered EPS insulation and flashings to existing isocyanurate insulation. Back out and remove all insulation fasteners and plates. Inspect existing isocyanurate insulation with Delmhorst meter and replace all wet and/or damaged insulation. Remove and properly dispose of edge metal, metal coping, gutters, downspouts, conductor heads, metal fascia cover, faceplates and metal counterflashing at locations shown on the Plans. Provide and install new wood blocking at locations shown on the Plans. Treat any rusted metal deck with rust inhibitor and replace any metal and/or wood deck which will not achieve proper pull results. Remove and reinstall/replace existing insulation around perimeter and penetrations as required to install new EPDM air barrier and high-density foam. Mechanically attach new 1.5" isocyanurate, 1/8" per foot tapered isocyanurate and 1/4" per foot isocyanurate crickets using fastener pattern shown on the Plans. In foam adhesive, provide and install new 1/2" cover board to new isocyanurate insulation using foam pattern shown on the Plans. Provide and install new .060", FR, non-reinforced, black, fully adhered EPDM Roof System with a 20-Year, No Dollar Limit, Warranty with 72 mph wind speed and 2" diameter Hail Warranty. Provide and install new Kynar 500 edge metal, metal coping, gutters, downspouts, fascia cover, conductor heads and metal counterflashing. Provide and install new overflow scuppers and faceplates at location shown on the Plans. All metal work shall meet ES-1 attachment requirements. Contractor shall include in Base Bid a \$20,000.00 Allowance for unforeseen conditions.

The Contractor shall prior to the start of installation of the work of this Section, secure a visit to the jobsite by a representative of the manufacturer of the roofing used who shall inspect and shall certify:

1. The surface to which the roofing is to be applied is in a condition suitable for this application.
2. The materials to be installed comply in all respects with the requirements of this Section of these Specifications.
3. The materials to be installed are in complete accordance with the Manufacturer's recommendations.

4. **The Contractor shall submit the Total System Roof Warranty Memorandum of Understanding to the Manufacturer with the order for Materials Submission. The Contractor and Roof System Manufacturer shall sign the Total System Roof Warranty Memorandum of Understanding located on Page 6 of this Section. Upon completion of the Project, provide the signed copy of the Total System Roof Warranty Memorandum of Understanding along with the Total System Warranty.**
- C. PROTECTION: Use all means necessary to protect roofing materials prior to, during and after installation. Store all roofing materials in a dry location, protected from the elements. Replace any damaged materials to the approval of the Designer at no additional cost to the Owner.
- D. BUILDING AND CONTENTS: The Roofer shall, at all times, take any and all steps necessary to keep the critical areas of the building and its contents in the dry during reroofing, using secured polyethylene covering.
- E. INSTALLER'S WARRANTY SIGNS
  1. Furnish and install one roof warranty sign at each School at location directed by Designer, 8.5"x11", made of .040 inch aluminum painted gloss white with gloss black lettering.
  2. Sign shall read: DO NOT MAKE REPAIRS, PENETRATIONS OR ALTERATIONS TO THIS ROOF without the written approval from the Owner or authorized Representative. The roof is maintained until (insert the month and 20 or 30 Years after the date of final acceptance) by (insert Manufacturer's name, address, and telephone number).
  3. Permanently post sign where directed by the Owner's Representative(s), prior to submission of, and as a condition for, final invoice and subsequent payment.

## PART 2 – PRODUCTS

- A. 1. The roof system shall be fully adhered, LSFR, .060" or .090" Black, Non-Reinforced EPDM Roof System. Approved Manufacturers:
- (a) Carlisle
  - (b) Elevate
  - (c) Johns Manville
  - (d) Versico
2. Pourable sealer for pipes shall be Elevate, Carlisle, Johns Manville or Versico. It shall be two separate components which when mixed together, shall be placed in pans and crowned to outside of pan to shed water. Provide prefinished rain-hat at top if used.
3. EPDM Beaded walk pads shall be Elevate, Carlisle, Johns Manville or Versico.
4. All bonding adhesive, splice cleaner, tape and other roofing items and accessories shall be approved by EPDM Manufacturer.
5. Two-component, polyurethane foam shall be Dow Froth Pak or equal approved by Designer.
6. 9" Wide peel and stick EPDM shall be Carlisle, Elevate, Johns Manville or Versico. Substrate shall be primed before applying EPDM. Peel and stick shall be sealed air tight when joining EPDM for barrier.
- B. INSTALLATION: All Roof installation shall have a 2-year Contractor's Warranty. .060" EPDM shall have a 20-Year, No Dollar Limit Warranty with 72 mph wind speed and 2" diameter Hail Warranty. .090" EPDM (Alternate only) shall have a 30-Year, No Dollar Limit Warranty with 72 mph wind speed, 2" diameter Hail Warranty and accidental puncture Warranty. 30-Year accidental puncture Warranty shall include 32 man hours per year. All Manufacturers costs associated with obtaining this Warranty shall be included in the Bid Price.

## PART 3 - EXECUTION

- A. INSPECTION: Prior to the installation of the Membrane Roofing System, verify that the area is completely free of debris which would hamper the installation of the roofing system. Verify that the membrane roofing may be installed in strict accordance with the original design, the Manufacturer's current recommendations and all

- pertinent Codes and Regulations.
- B. **INSTALLATION:** Install all membrane roofing in strict accordance with the original design, the Manufacturer's current recommendations, and all pertinent Codes and Regulations.
- C. **TEST CUT:** The Owner reserves the right to require that test cuts be made to verify that the installation has been performed in accordance with the stated requirements.
- D. **REPAIRS AND REPLACEMENTS:** If the same is immediately approved by the Designer, patch the area or areas of such test cuts to whatever size and dimension as is needed to insure the specified longevity of the roof. If the sample is not, for any reason, immediately approved by the Designer, furnish and install all temporary protection needed to prevent penetration of water through the roof until final patches or new roofs have been installed. Upon decision of the Designer, immediately make all repairs and/or replacements necessary to insure compliance with the provisions of this Section of these Specifications. Make all test cuts, patching and required repairs and replacements at no additional cost to the Owner. The roof shall be a Roof Membrane System which is capable of being warranted for twenty or thirty years.
- E. **GUARANTEE:** The Roofing Contractor and material supplier hereby unconditionally guarantee the roofing system to be completely free of defects from either material, installation or other reasons for a period of two (2) years. .060" EPDM shall have a 20-Year, No Dollar Limit Warranty with 72 mph wind speed and 2" diameter Hail Warranty. .090" EPDM (Alternate only) shall have a 30-Year, No Dollar Limit Warranty with 72 mph wind speed, 2" diameter Hail Warranty and accidental puncture Warranty. 30-Year puncture Warranty shall include 32 man hours per year. All Manufacturers costs associated with obtaining this Warranty shall be included in the Bid Price.
- F. **CLEANING UP:** Take special care to prevent splashing bitumen onto adjacent surfaces, and remove immediately all traces of such splashed and/or spilled material. Upon completion of the work of this Section, immediately remove all debris from the job site.
- G. Keep all roofing materials dry and properly stored, using tied tarpaulin-- plastic is not acceptable. Do not work in temperatures less than 40 degrees F. Do not work during or after precipitation, while materials are subject to moisture involvement.

- H. Keep accurate records of overnight cutoffs, dates and areas, and conditions of work.
- I. During the reroofing Project, Contractor shall provide and install all means necessary to prevent the penetration of water into the existing or new roof system. Any failure of these means to prevent water from entering the existing or new roof system that produces a leak or water entry into the new roof system shall be grounds for the Owner and Designer to demand that the Contractor cut out and properly replace all wet materials in the roof system at that time at the Contractor's expense. All wet materials in the new roof shall be cut out and properly replaced with dry materials in all directions until acceptable materials are found everywhere.
- J. Designer may conduct a nondestructive moisture scan upon completion of the Project. If wet insulation is found, Contractor shall properly cut out and remove all wet materials and repair roof at Contractor's expense. If no moisture is found in the Roof, there will be no charge for the scan. If moisture is found in the Roof, Contractor shall pay for moisture scan.
- K. Contractor shall replace only deck which is required for the installation of a quality roof system, i.e., to pass pull-out tests, or properly support and secure the roof system. The actual square footage of deck replacement will be field-verified.
- L. Wind Warranty shall be 72 mph. Warranty shall have a 2" diameter Hail Warranty.
- M. Roof Warranty shall be a Total System Warranty which shall cover all materials, installation and workmanship. Manufacturer shall be responsible for taking all steps required to insure that the Warranted Roof System meets all the Manufacturer's requirements for Warranty issuance, including the proper installation of the Roof System by Roofing Contractors authorized, trained and approved for the installation of the Manufacturer's Warranted Roof System.



# RCR&A

## RICHARD C. RINKS & ASSOCIATES, INC.

Engineering and Architectural Services

Building Enclosure Consultants

ASCE - NSPE - TSPE - IIBEC - EDI

30 North Jefferson Avenue - Cookeville, Tennessee 38501

Telephone 931-528-5543 [Rinks-Consulting.com](http://Rinks-Consulting.com) Facsimile 931-528-5544

DATE \_\_\_\_\_ ROOFING PROJECT: Roof Replacement – Middle School Auditorium

RCR&A PROJECT NO.: 2971

ROOF AREA (SF): 12,655

### 20 or 30 YEAR TOTAL SYSTEM ROOF WARRANTY MEMORANDUM OF UNDERSTANDING

Remove and properly dispose of all debris, EPDM roof membrane and flashings to existing isocyanurate insulation. Inspect existing isocyanurate insulation with Delmhorst meter and replace all wet and/or damaged insulation. Mechanically attach new isocyanurate insulation. In foam adhesive, provide and install new 1/2" cover board to new isocyanurate insulation. Provide and install new .060", FR, non-reinforced, black, fully adhered EPDM Roof System with a 20 or 30 Year, No Dollar Limit Warranty with 72 mph wind speed and 2" diameter Hail Warranty.

The Roofing Contractor Certifies that the Roof System specified for this Project was installed in strict accordance with the Manufacturer's recommendations utilizing only Manufacturer's approved Products to install the Roof System and insured that all products were protected prior to installation and insured that all products in the Roof System meet all applicable standards and had no moisture or water trapped in the Roof System. The Roofing Contractor further Certifies that all steps necessary were taken to insure that all conditions were met for the issuance of the Total System Roof Warranty by the Manufacturer.

\_\_\_\_\_  
Roofing Contractor

\_\_\_\_\_  
Signed by

\_\_\_\_\_  
Authorized Title

\_\_\_\_\_  
Date

The Roofing Manufacturer warrants that if the Manufacturer cannot supply a specified product for inclusion in a Total System Warranty, the installing contractor must obtain written approval from the Manufacturer for all products not supplied by the Manufacturer to be incorporated into the Manufacturer's full system warranty. With written approval, the Manufacturer will issue a Total System Roof Warranty. In addition to a final inspection of the completed installation as required by the Manufacturer, the Manufacturer is also entitled to supplement their field final inspection with the Roofing Contractor's above certification. The purpose of this Memorandum of Understanding is to ensure that over the life of the Warranty, there will be NO exceptions or exclusions to the Total System Warranty based upon products used or installation issues by the Manufacturer's approved Roofing Contractor, provided all materials installed are provided or approved by the Manufacturer.

\_\_\_\_\_  
Roofing System Manufacturer Issuing the Total System Warranty

\_\_\_\_\_  
Signed by

\_\_\_\_\_  
Authorized Title

\_\_\_\_\_  
Date

07500-6

**END OF SECTION**

## PART 1 - GENERAL

- A. SUBMITTALS REQUIRED: SHOP DRAWINGS(X); MATERIALS LIST(X); SAMPLES( ); MANUALS( ); CERTIFICATES( ); OTHER( )
- B. SCOPE: Furnish and install all Flashing and Sheet Metal as shown on the Drawings or as specified herein.
- C. QUALITY ASSURANCE:
1. Provide workmen who are familiar with the materials and methods of flashing and sheet metal work.
  2. Comply with all pertinent Codes and Regulations and recommendations contained in "Architectural Sheet Metal Manual," latest edition, of the Sheet Metal and Air Conditioning Contractors National Association, Inc.
  3. Upon request of the Designer, demonstrate by hose or standing water that all flashing and sheet metal is completely watertight.
- D. PRODUCT HANDLING: Protect the materials of this Section before, during, and after installation, and protect the installed work and materials of all other trades. In the event of damage, immediately make all repairs and replacements necessary to the approval of the Designer and at no additional cost to the Owner.

## PART 2 - PRODUCTS

- A. MATERIALS AND GAUGES: Where sheet metal is required and no material or gauge is indicated on the Drawings, furnish and install the highest quality and weight commensurate with the referenced standards set by SMACNA. Provide 30-year finish warranty on all new sheet metal. **Unless noted otherwise, all low slope perimeter/edge metal, wood blocking and coping shall meet or exceed Code required ES-1 attachment requirements.**

- B. **EDGE METAL:** New edge metal shall be Elevate (AnchorGard SP Fascia, Detail RE-1), Carlisle (SecurEdge 2000 Standard Butyl Strip Fascia), Versico (Versitrim 2000) or Johns Manville (Presto-Tite Edge One Fascia System).
- C. **FASCIA COVER:** Fascia cover shall be 24 ga., prefinished Kynar 500 and shall match fascia system color. Fastener securing fascia cover shall be match metal color and have an EPDM gasket.
- D. **NAILS, RIVETS, AND FASTENERS:**
- Use only rivets and nails recommended for use with the metal flashing. Fasteners used in copper solution preservative wood shall be stainless steel fasteners.
- E. **OTHER MATERIALS:** All other materials not specifically described but required for a complete and proper installation of flashing and sheet metal shall be new first quality of their respective kinds and subject to the approval of the Designer.

### PART 3 - EXECUTION

- A. **SURFACE CONDITIONS:**
1. Prior to all work of this Section, carefully inspect the installed work of all other trades and verify that all such work is complete to the point where this installation may properly commence. Verify that flashing and sheet metal may be installed in accordance with the original design, all pertinent Codes and Regulations, the referenced standards, and the approved Shop Drawings.
  2. In the event of discrepancy, immediately notify the Designer. Do not proceed with installation in areas of discrepancy until all such discrepancies have been fully resolved.
- B. **WORKMANSHIP:**
1. Form all sheet metal accurately to the dimensions and shapes required, finishing all molded and broken surfaces with true, sharp, and straight lines and angles and, where intercepting other members, coping to an accurate fit and soldering securely.

Unless otherwise specifically permitted by the Designer, turn all exposed edges back ½-inch.

2. Form, fabricate, and install all sheet metal so as to adequately provide for expansion and contraction in the finished work.
3. Weatherproofing: Finish watertight and weather-tight where so required. Make all lock seam work flat and true to line and sweated full of solder. Make all lock seams, when soldered, at least ½-inch wide. Where lap seams are not soldered, lap according to pitch, but in no case less than three inches. Make all flat and lap seams in direction of flow.
4. Joints: Join parts with rivets or sheet metal screws where necessary for strength or stiffness. Provide suitable watertight expansion joints for all runs of more than 40-feet except where closer spacing is indicated on the Drawings or required for proper installation. Longitudinal seams in caps, copings, etc., shall be standing-seam joints.
5. Nailing: Whenever possible, secure metal by means of clips or cleats without nailing through the metal.  
In general, space all nails, rivets, and screws not more than 8-inches apart and, where exposed to the weather, use lead washers. For nailing into wood, use barbed roofing nails 1-1/4 inches long by 11-gauge. For nailing into concrete, use drilled plug holes and plugs.
6. Soldering: Thoroughly clean and tin all joint materials prior to soldering. Perform all soldering slowly with a well-heated heavy soldering copper of blunt design, properly tinned for use, in order to heat the seams thoroughly and to completely fill them with solder. Make all exposed soldering on finished surfaces neat, full flowing, and smooth. After soldering, thoroughly wash acid flux with a soda solution.

END OF SECTION

## PART 1 - GENERAL

- A. SUBMITTALS REQUIRED: SHOP DRAWINGS( ); MATERIALS LIST(X); SAMPLES( ); MANUALS( ); CERTIFICATES( ); OTHER( )
- B. QUALITY ASSURANCE:
1. Installation of caulking shall be performed only by workmen thoroughly skilled and specially trained in the techniques of caulking, and who are completely familiar with the published recommendations of the manufacturer of the caulking materials being used.
  2. Indication of lack of skill on the part of caulking installers shall be sufficient grounds for the Designer to reject installed caulking and to require its immediate removal and complete recaulking at no additional cost to the Owner.
- C. PRODUCT HANDLING: Protect the materials of this Section before, during, and after installation, and protect the installed work and materials of all other trades. In the event of damage, immediately make all repairs and replacements necessary to the approval of the Designer and at no additional cost to the Owner.
- D. DESCRIPTION: The purpose of caulking in this work is to provide a positive barrier against penetration of air and moisture at joints between items where caulking is essential to continued integrity of the barrier. Such caulking will normally be performed under the work of various Sections of the Specifications, but shall be performed in strict accordance with the provisions of this Section. Individual requirements for caulking are described in various other Sections of these Specifications.

## PART 2 - PRODUCTS

- A. CAULKING MATERIALS: All caulking materials, unless otherwise specifically approved by the Designer, shall be Dow 790 or Dow 795.
- B. CAULKING EQUIPMENT: All caulking equipment shall be only such equipment as is specifically recommended by the manufacturer of the caulking material being installed.

## PART 3 - EXECUTION

## A. SURFACE CONDITIONS:

1. Prior to all work of this Section, carefully inspect the installed work of all other trades and verify that all such work is complete to the point where this installation may properly commence. Verify that caulking may be installed in accordance with the Manufacturer's recommendations.
2. In the event of discrepancy, immediately notify the Designer. Do not proceed with installation in areas of discrepancy until all such discrepancies have been fully resolved.

B. CHOICE OF CAULKING MATERIAL: Use only that caulking material which is best suited to the installation and is so recommended by the caulking material manufacturer.

## C. BACK-UP MATERIALS:

1. Verify the compatibility of filler material with caulking before installation. Use filler about one third to one half wider than width of joint so sufficient pressure is exerted by filler to provide substantial resistance to displacement.
2. All filler materials shall be closed cell, foam back rod or other filler completely compatible with the caulking material.

D. APPLICATION OF CAULKING: Install caulking in strict accordance with the Manufacturer's recommendations, taking care to produce beads of proper width and depth, to tool as recommended by the manufacturer, and to immediately remove all surplus caulking.

E. CAULKING SCHEDULE: Carefully study the Drawings and furnish and install the proper caulking at each point where called for on the Drawings, plus at all other points where caulking is essential in maintaining the continued integrity of the watertight barrier.

END OF SECTION

## PART 1 - GENERAL

A. SUBMITTALS REQUIRED: SHOP DRAWINGS( ); MATERIALS LIST( ); SAMPLES(X); MANUALS( ); CERTIFICATES( ); OTHER(X) COLOR CHARTS

B. SCOPE: Furnish and install all Painting as shown on the Drawings or as specified herein.

C. MANUFACTURER'S RECOMMENDATIONS:

In each case where material proposed is not the material specified or specifically described as an acceptable alternate in this Section of these Specifications, submit for the Designer's review the current recommended method of application published by the manufacturer of the proposed material.

D. QUALITY ASSURANCE:

1. Codes and Standards: In addition to complying with all pertinent codes and regulations, comply with "Standard (Type 1)," as defined by the Painting and Decorating Contractors of America in their "Modern Guide to Paint Specifications," latest edition.

2. Qualifications of Painters: Use only qualified journeyman painters for the mixing and application of paint on exposed surfaces; in the acceptance or rejection of installed painting, no allowance will be made for lack of skill on the part of painters.

E. PRODUCT HANDLING: Protect the materials of this Section before, during, and after installation, and protect the installed work and materials of all other trades. In the event of damage, immediately make all repairs and replacements necessary to the approval of the Designer and at no additional cost to the Owner.

F. EXTRA STOCK: Upon completion of this portion of the work, deliver to the Owner an extra stock of paint equaling approximately one gallon of each color used in each coating material used, with all such extra stock tightly sealed in clearly labeled containers.

- G. **COLOR SCHEDULE:** Paint colors shall be as selected by the Owner from manufacturer's complete color selection. The Contractor shall provide the Designer with color samples of the chosen manufacturer. Before any work is done, the Designer will furnish the Contractor with a set of color cards and a schedule showing where the various colors shall go.

## PART 2 - PRODUCTS

- A. **PAINT MATERIALS:** All paint materials selected for coating systems for each type of surface shall be the product of a single manufacturer. All paint materials and equipment shall be compatible in use: finish coats shall be compatible with prime coats; prime coats shall be compatible with the surface to be coated; and all tools and equipment shall be compatible with the coating to be applied. All paint shall be delivered to the site in manufacturer's sealed containers. Each container shall be labeled by the manufacturer; labels shall give manufacturer's name, type of paint, color of paint, and instructions for reducing.
- B. **PAINTING MANUFACTURERS:**
1. **Primer:** Sherwin Williams Uniflex Rust Inhibitive Metal Primer, or approved equal.
  2. **Exterior Paint:** Sherwin Williams Industrial Enamel, or approved equal (color to be selected by Owner).
  3. **Aluminum Coating:** Sherwin Williams Silver Brite Aluminum, or approved equal.
  4. **EPDM:** Sherwin Williams Latex or Acrylic Paint, similar Porter Paint, similar Benjamin Moore paint or approved equal.
- C. **PAINT SCHEDULE**

MATERIAL  
Exposed Steel

SHEEN  
satin

COATS  
Primer, 2 exterior enamel



## PART 3 - EXECUTION

## A. SURFACE CONDITIONS:

1. Prior to work of this Section, inspect the installed work of other trades. Verify that paint finishes may be applied in strict accordance with all pertinent Codes and Regulations and the requirements of these Specifications.
2. In the event of discrepancy, immediately notify the Designer. Do not proceed.

## B. PREPARATION OF SURFACES, GENERAL:

1. Prior to all surface preparation and painting operations, completely mask, remove, or otherwise adequately protect all surfaces not scheduled to receive paint.
2. Before applying paint or other surfaces treatment, thoroughly clean all surfaces involved. Schedule all cleaning and painting so that dust and other contaminants from the cleaning process will not fall on wet newly-painted surfaces.

## C. PREPARATION OF METAL SURFACES: Galvanized Metal: Clean all surfaces thoroughly with solvent until they are completely free from dirt, oil, and grease. Thoroughly treat the cleaned surface with phosphoric acid etch. Remove all excess etching solution and allow to dry completely before applying paint.

## D. PAINT APPLICATION:

1. Drying: Allow sufficient drying time between coats. Modify the period, as recommended by the material manufacturer, to suit adverse weather conditions.
2. Environmental Conditions: Comply with the manufacturer's recommendations as to environmental conditions under which the coating systems may be applied. Do not apply paint in areas where dust is being generated.

3. Moisture Meter: Use a moisture-meter approved by the Designer to test surfaces. Do not apply the initial coating until the moisture meter reading is within limits recommended by the paint materials manufacturer. Sand and dust between coats to remove all defects visible to the unaided eye from a distance of five feet. Slightly vary the color of succeeding coats.
- E. INSPECTION: Do not apply additional coats until completed coat has been inspected and approved by the Designer. Only inspected and approved coats of paint will be considered in determining the number of coats applied.
  - F. DRY MIL THICKNESS: Provide and use a "Tooke Dry Film Thickness Gauge", or other gauge approved by the Designer, to prove the dry mil thickness of paint applied.
  - G. REINSTALLATION OF REMOVED ITEMS: Following completion of painting in each area, promptly reinstall all items removed for painting, using only workmen skilled in the particular trade.
  - H. CLEANING UP: During progress of the Work, do not allow the accumulation of empty containers or other excess items, except in areas specifically set aside for that purpose. Prevent accidental spilling of paint materials, and in event of such spill, immediately remove all spilled material and the waste or other equipment used to clean up the spill, and wash the surfaces to their original undamaged condition, all at no additional cost to the Owner.
  - I. In all cases, complete coverage of painted areas will be required--with no ghosts or lack of color coverage being accepted. Apparent brush or roller marks must not be visible in the finished product. Should additional coats be required for a first-class finish, they shall be applied at no additional cost to the Owner.
  - J. Painting shall be 100 percent complete prior to requesting punch list from Designer. If painting quality is not a first-class job, Designer will:
    1. Terminate punch list preparation and bill Contractor for Designer's cost.
    2. Continue at Contractor's option punch list preparation and bill Contractor for Designer's cost.

END OF SECTION







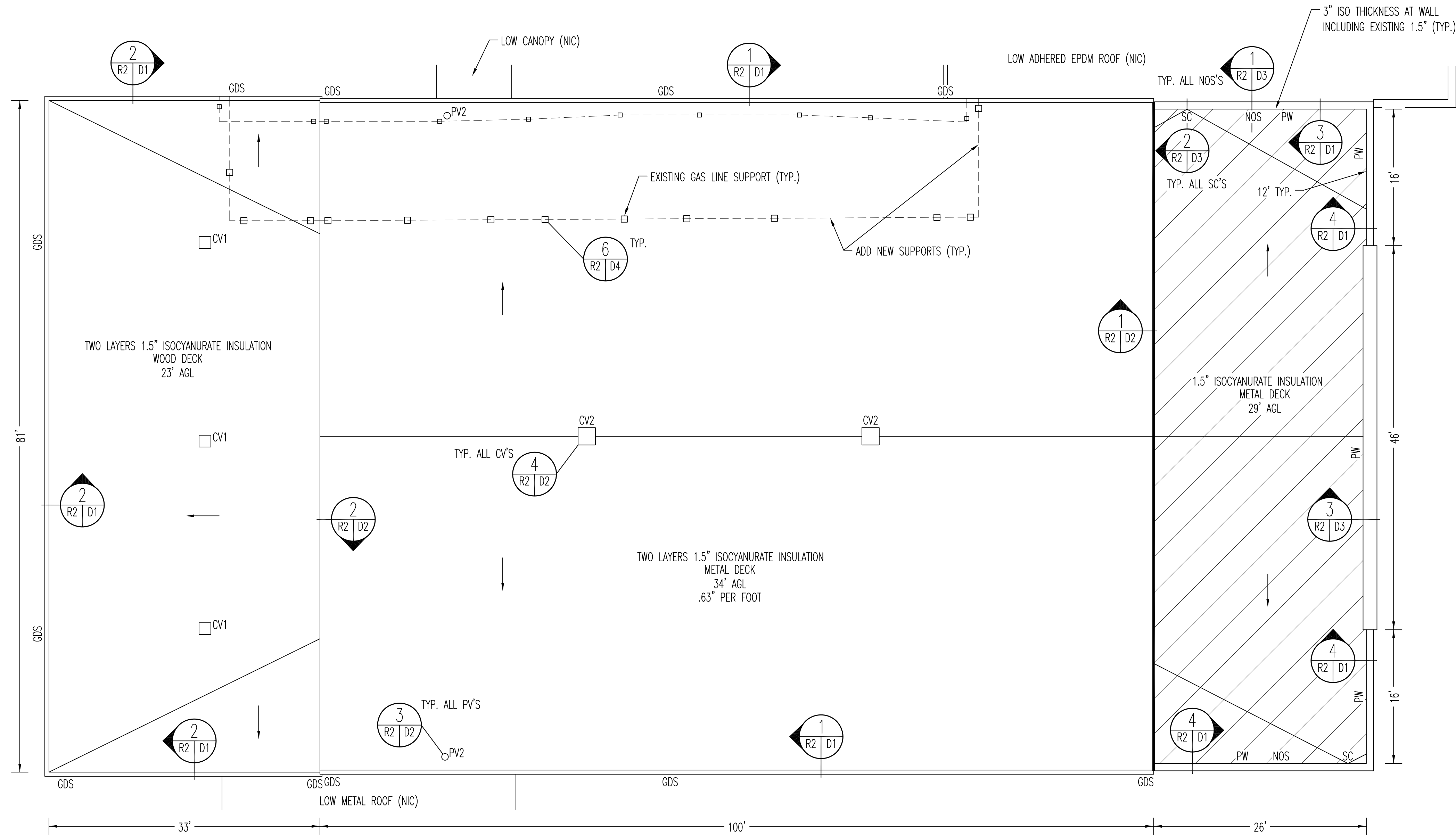

**CORNERS AND PERIMETERS**  
 23' AGL ROOF  
 8'x8' CORNER AND 8' WIDE PERIMETER  
 29' AND 34' AGL ROOFS  
 12'x12' CORNER AND 12' WIDE PERIMETER  
 SEE DETAILS 3, 4 AND 5/D4

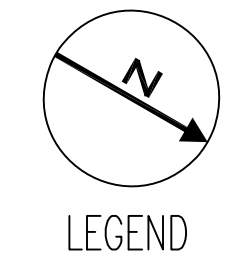

- LEGEND**
- PW PARAPET WALL
  - CV1 1.5'x1.5' CURBED VENT
  - CV2 2'x2' CURBED VENT
  - GDS NEW GUTTER DOWNSPOUT
  - PV2 2" PLUMBING VENT
  - SC NEW 10"x10" SCUPPER, CONDUCTOR HEAD AND DOWNSPOUT
  - NOS NEW 12" WIDE x 6" TALL OVERFLOW SCUPPER
  - - - EXISTING GAS LINE
  - /// NEW TAPERED INSULATION/CRICKETS
  - ▬▬▬ NEW .060" EPDM WALL FLASHING

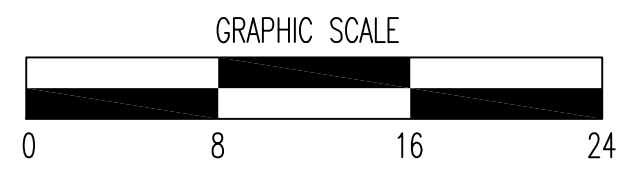

ROOF SLOPE 1/8" PER FOOT U.N.O.  
 ROOF HEIGHT ABOVE GROUND LEVEL VARIES 23 TO 34 FEET (AGL)  
 TOTAL APPROXIMATE ROOF AREA IN S.F. 12,656  
 APPROXIMATE ROOF AREA WITH METAL DECK IN S.F. 10,035  
 APPROXIMATE ROOF AREA WITH WOOD DECK IN S.F. 2,620

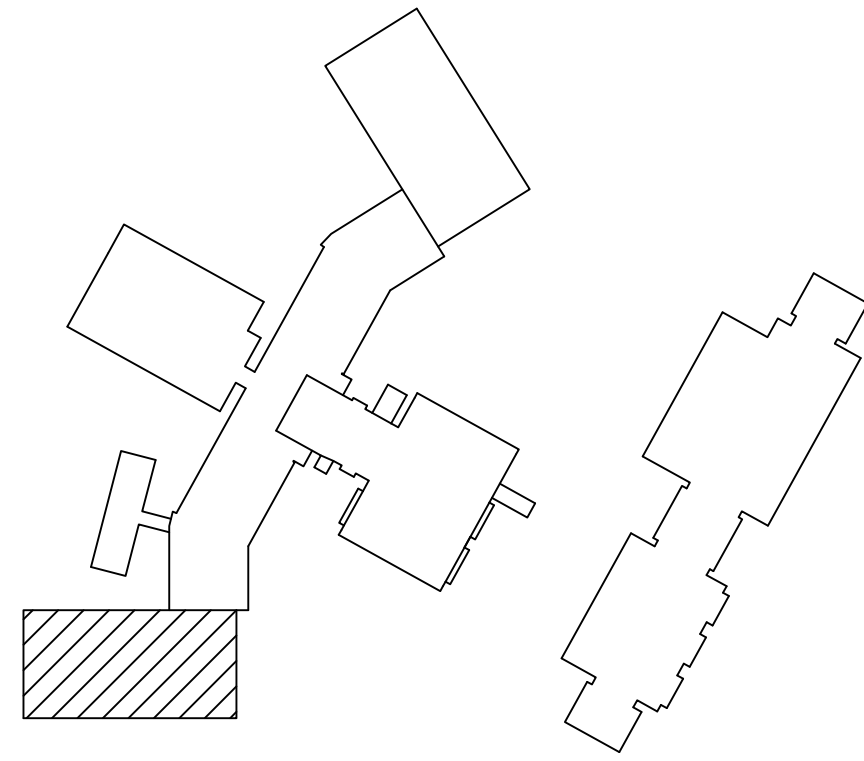

KEY PLAN

**NEW ROOF PLAN**  
 SCALE: 1/8" = 1'-0"

DR: RFR	CK: RCR	PROJ. NO.: 2971	DATE: 5-1-23
WARREN-23\NRP.DWG			REVISIONS
NO.	DATE	REMARKS	

**Richard C. Rinks & Associates, Inc.**  
 Engineering and Architectural Services  
 Building Enclosure Consultants  
 ASCE · NSPE · TSPE · IIBEC · EDI  
 30 North Jefferson Avenue (38501) P.O. Box 691 (38503)  
 Cookeville, Tennessee  
 Telephone 931-528-5543 Rinks-Consulting.com Facsimile 931-528-5544

ROOF REPLACEMENT  
 MIDDLE SCHOOL AUDITORIUM  
 McMinnville, Tennessee  
 FOR  
 WARREN COUNTY SCHOOLS  
 MAY 1, 2023  
 NEW ROOF PLAN

SCALE: 1/8" = 1'-0"

R2 SHEET 4 OF 8

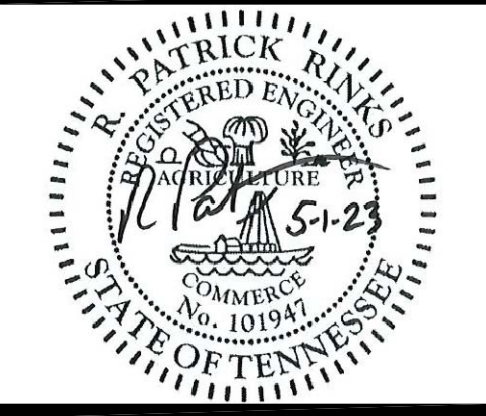

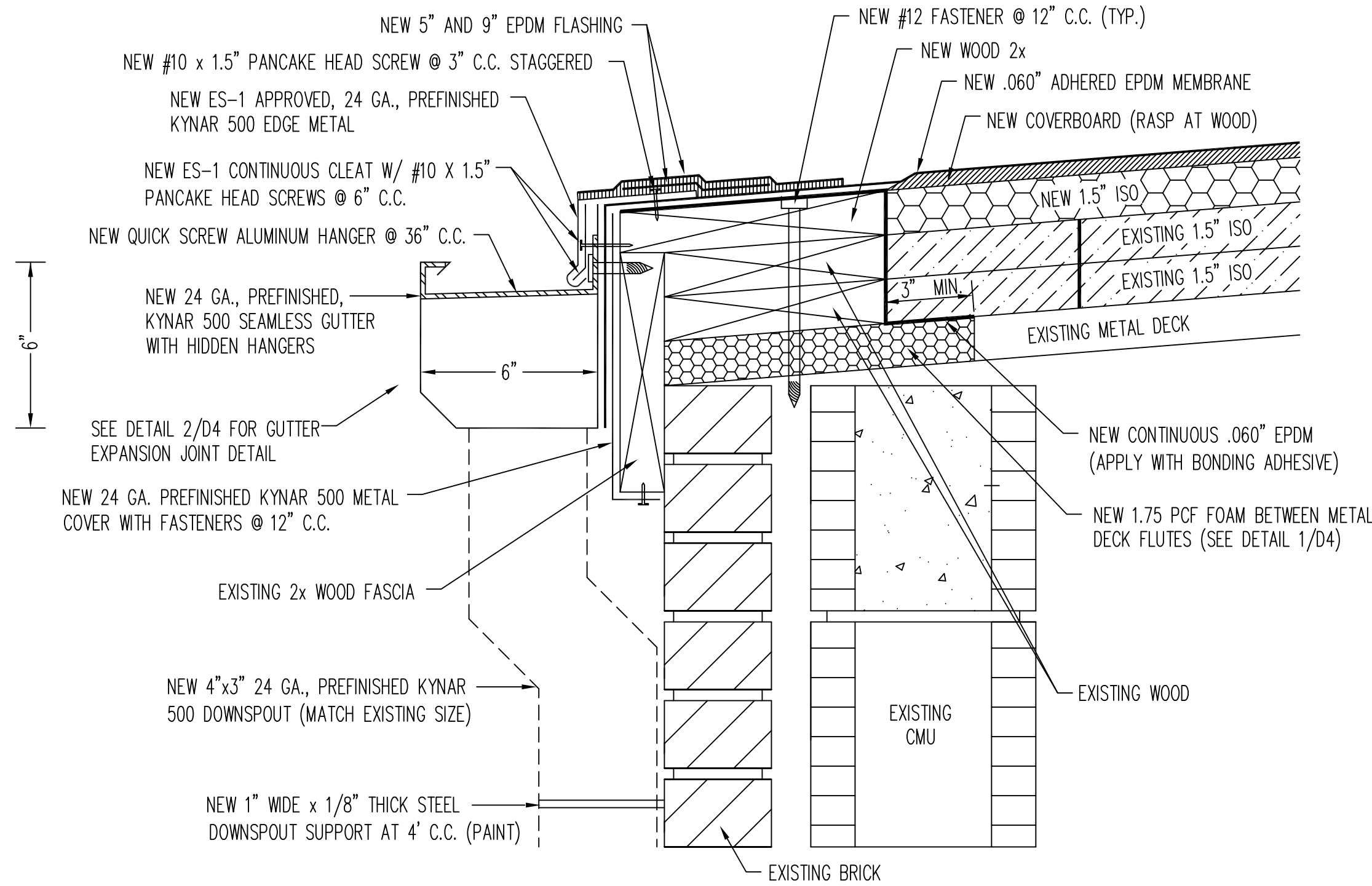

1 GUTTER DETAIL (METAL DECK) (GDS)  
 SCALE: 3" = 1'-0"

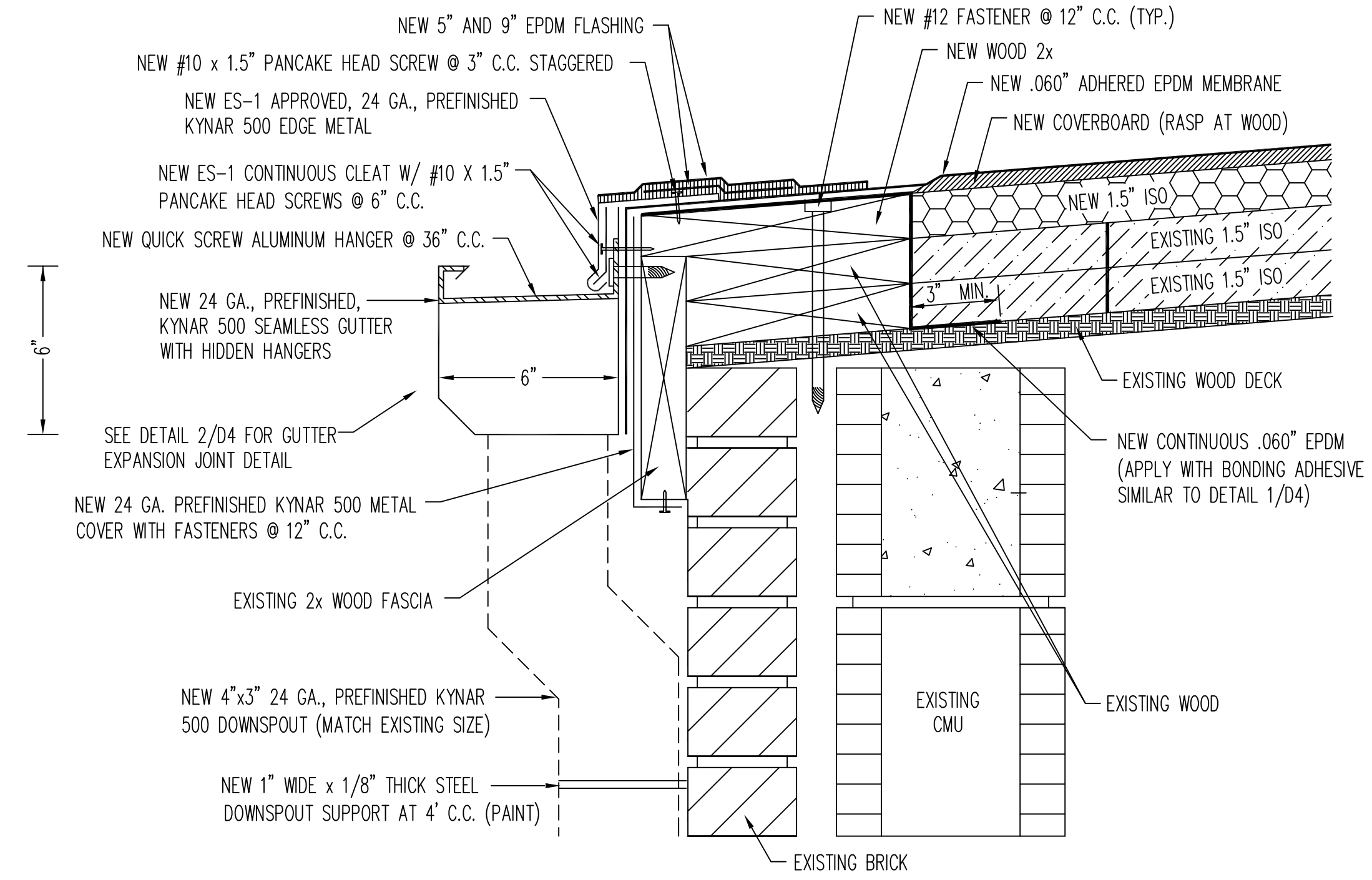

2 GUTTER DETAIL (WOOD DECK) (GDS)  
 SCALE: 3" = 1'-0"

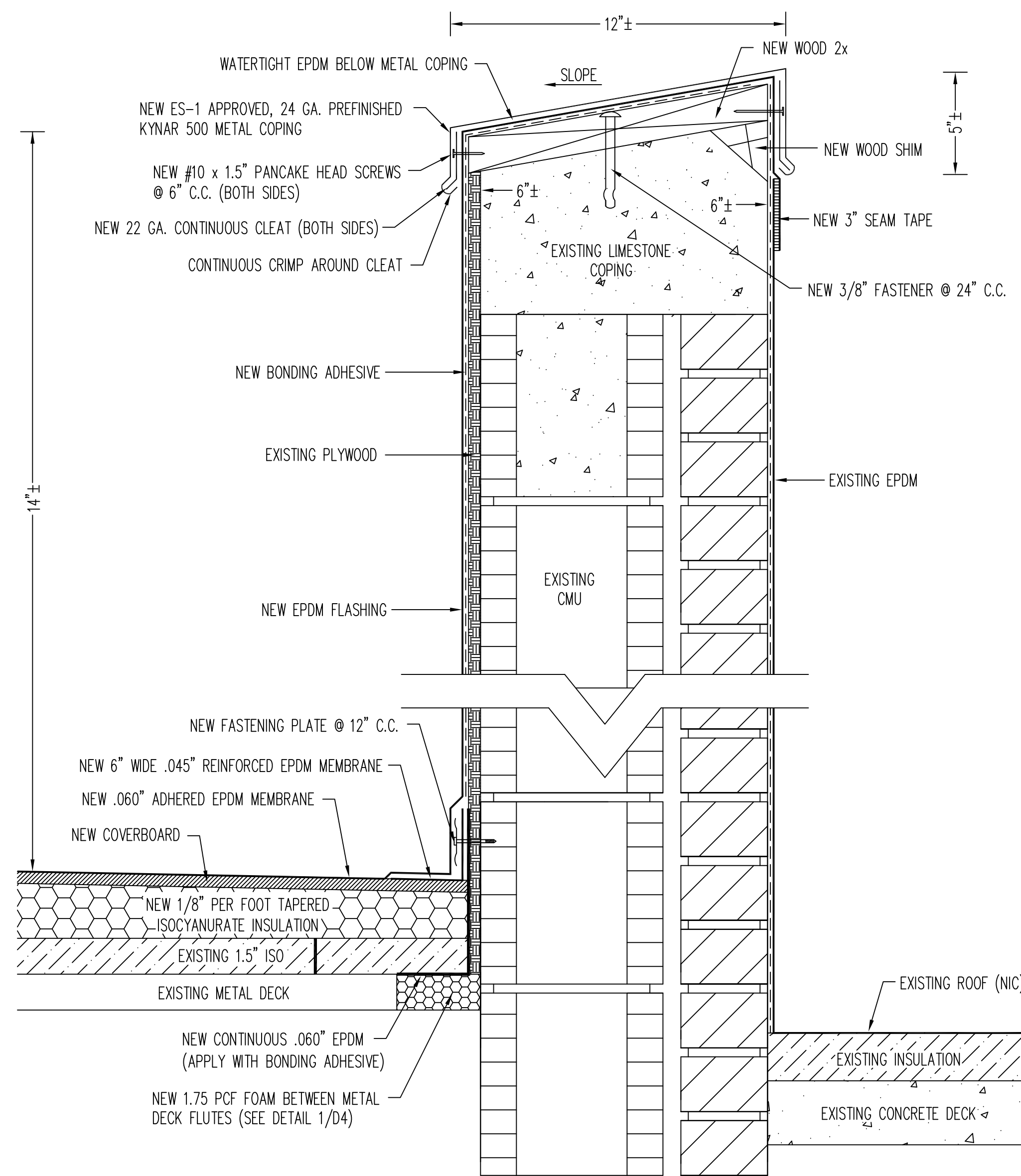

3 WALL FLASHING (PW)  
 SCALE: 3" = 1'-0"

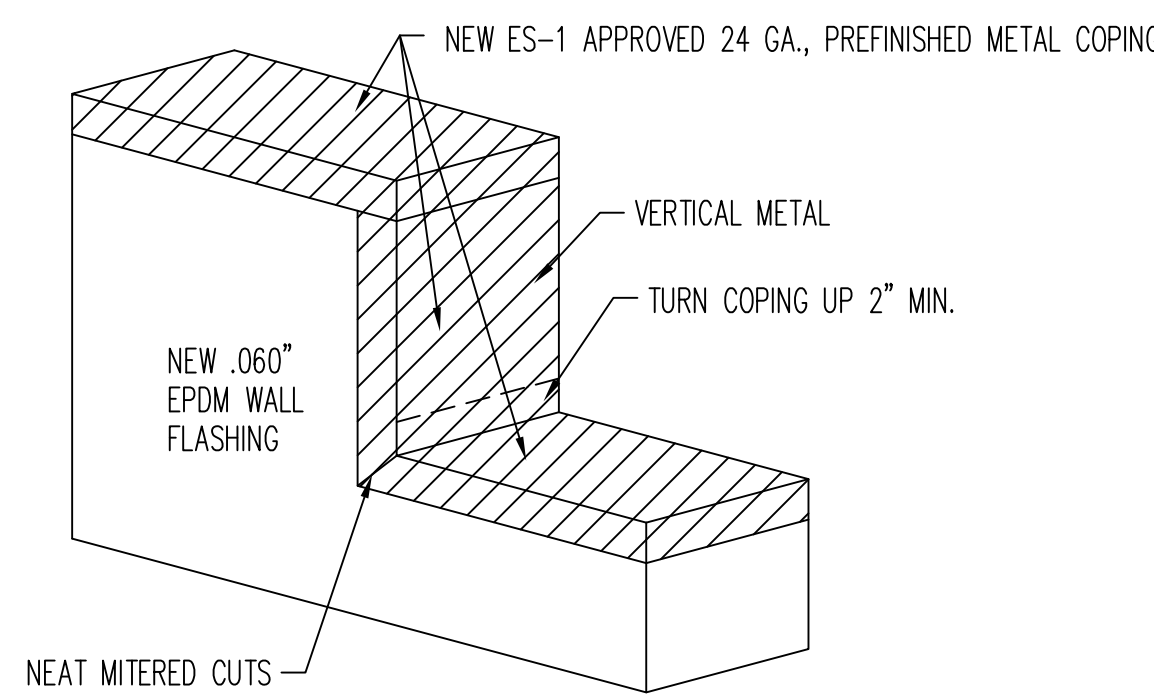

METAL COPING AT STEP DOWN

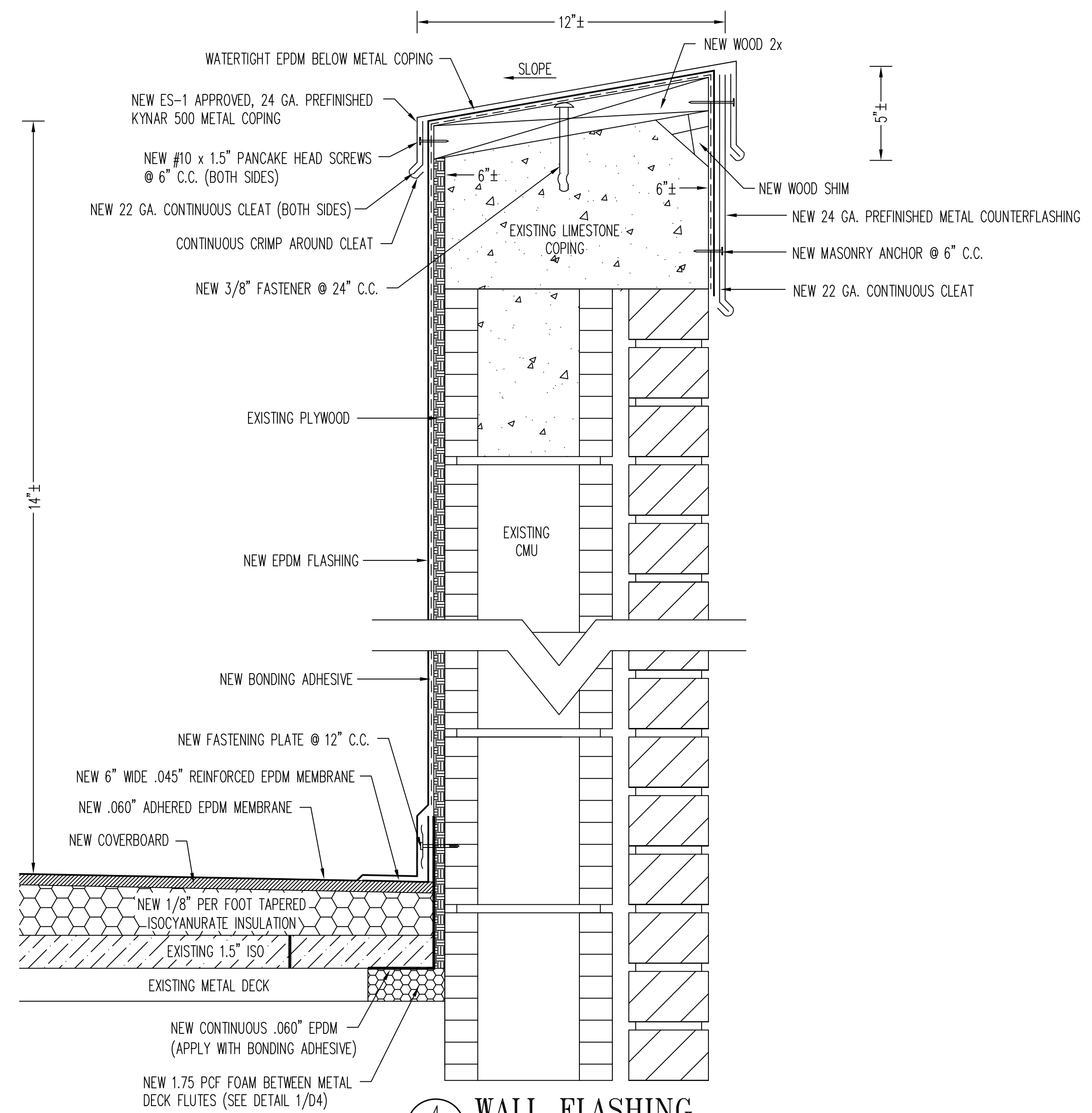
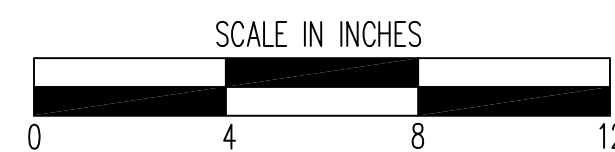

4 WALL FLASHING (PW)  
 SCALE: 3" = 1'-0"

DR: JAY CK: ROR PROJ. NO.: 2971 DATE: 5-1-23

REVISIONS

NO.	DATE	REMARKS

**Richard C. Rinks & Associates, Inc.**  
 Engineering and Architectural Services  
 Building Enclosure Consultants  
 ASCE · NSPE · TSPE · IIBEC · EDI  
 30 North Jefferson Avenue (38501) P.O. Box 691 (38503)  
 Cookeville, Tennessee  
 Telephone 931-528-5543 Rinks-Consulting.com Facsimile 931-528-5544

ROOF REPLACEMENT  
 MIDDLE SCHOOL AUDITORIUM  
 McMinnville, Tennessee  
 FOR  
 WARREN COUNTY SCHOOLS  
 MAY 1, 2023  
 NEW ROOF DETAILS

SCALE: AS SHOWN  
 D1 SHEET 5 OF 8

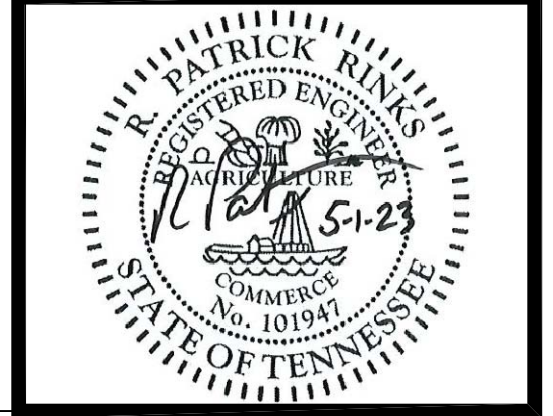

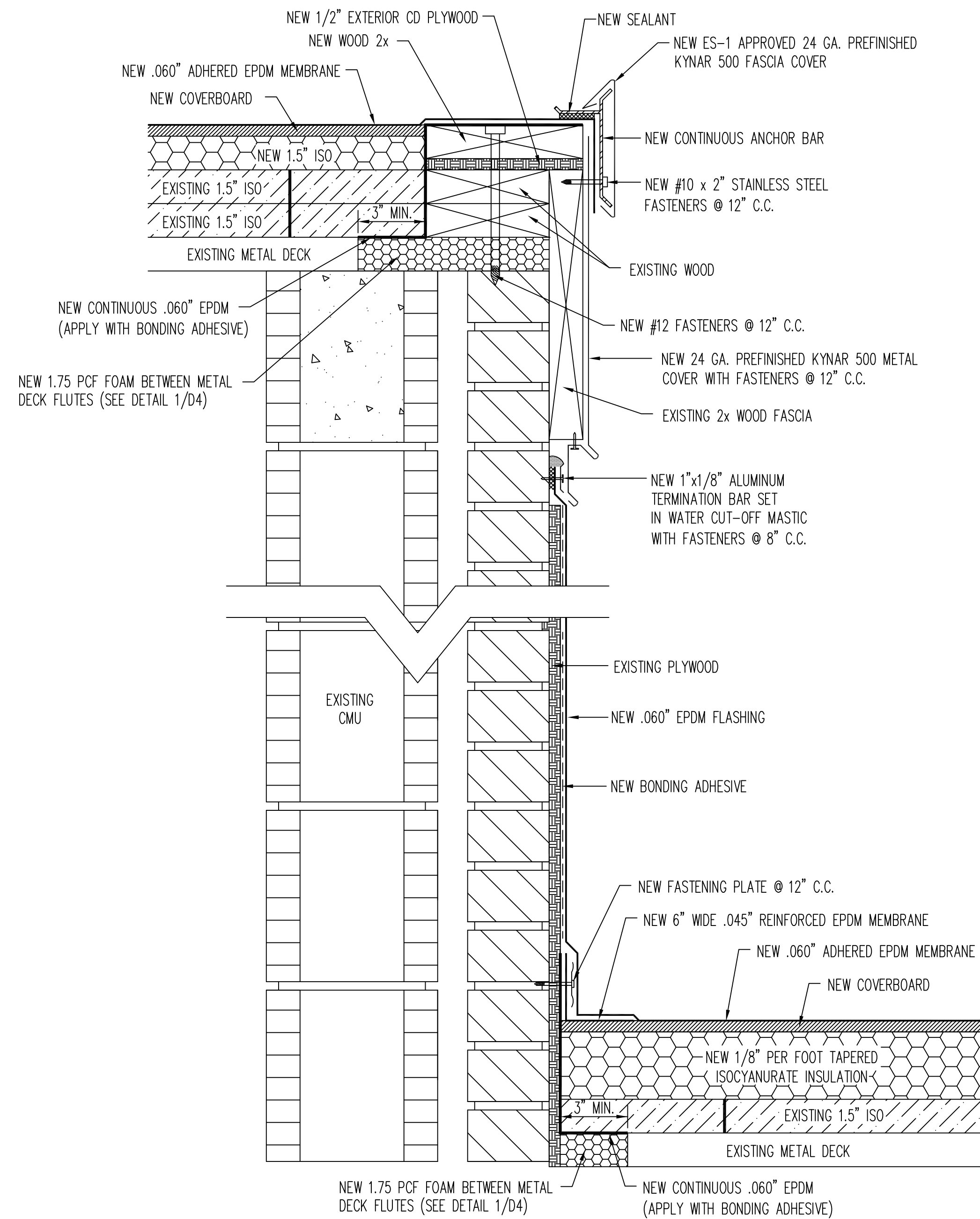

**1 WALL FLASHING**  
 SCALE: 3" = 1'-0"

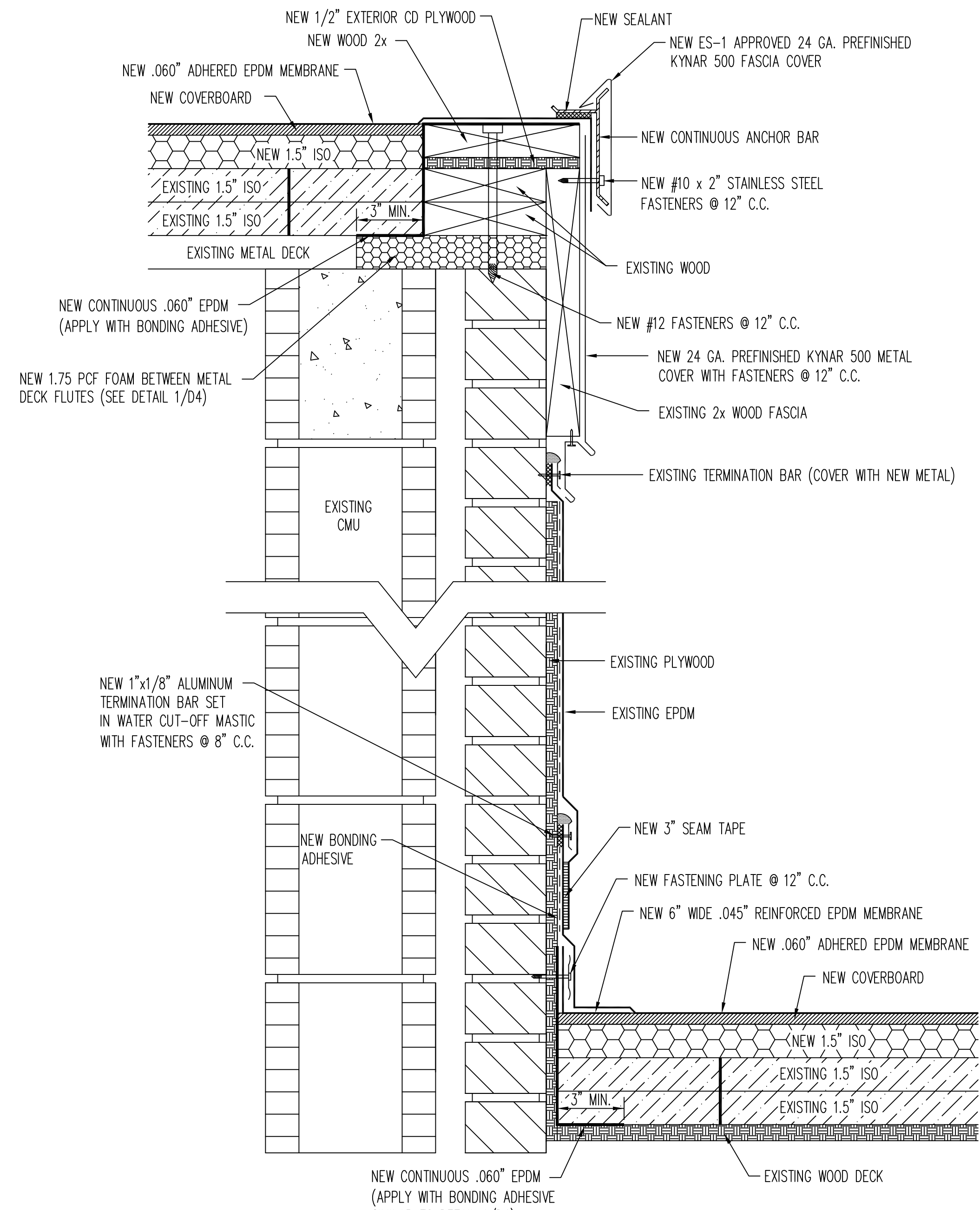

**2 WALL FLASHING**  
 SCALE: 3" = 1'-0"

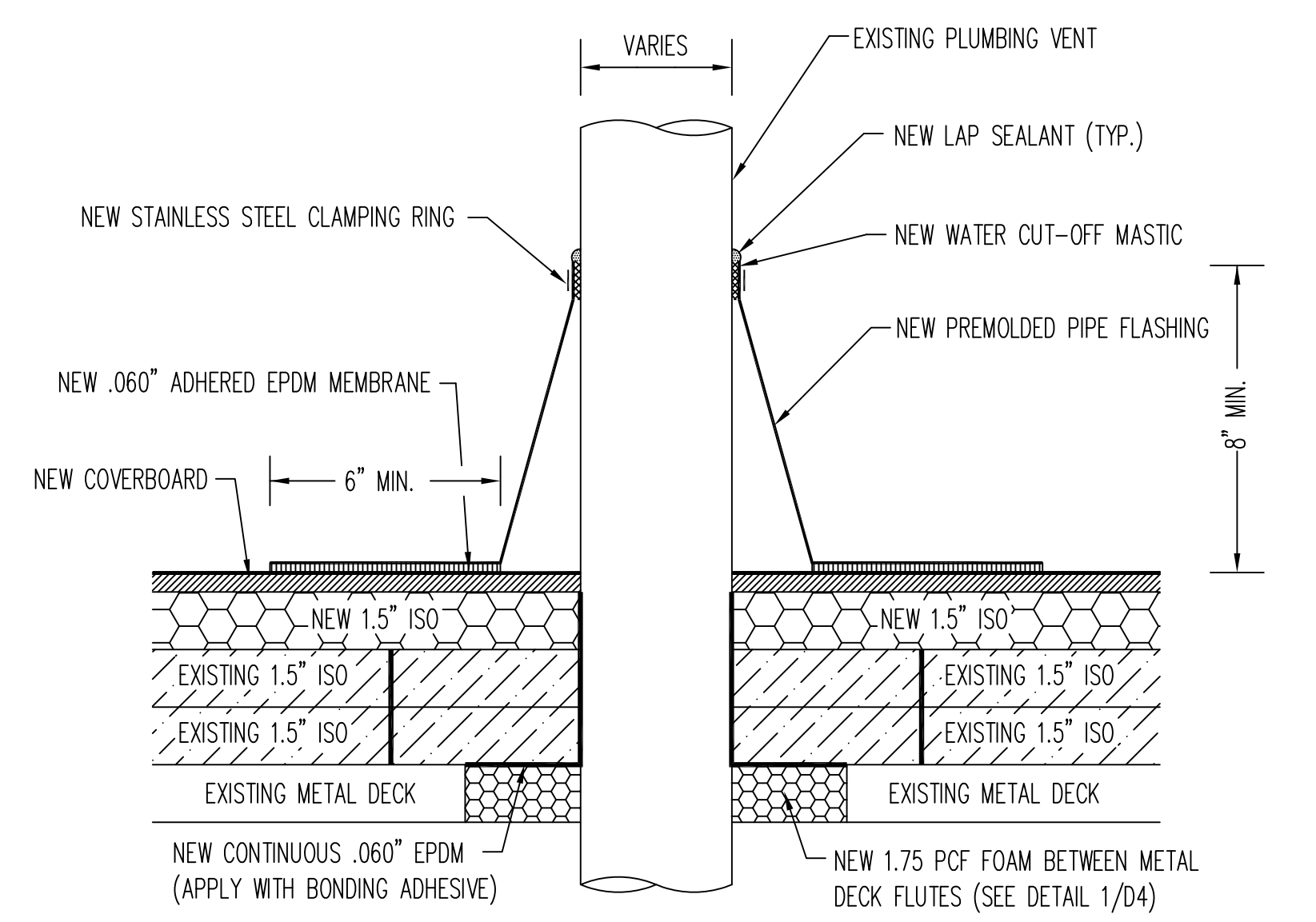

**3 PLUMBING VENT DETAIL**  
 SCALE: 3" = 1'-0"

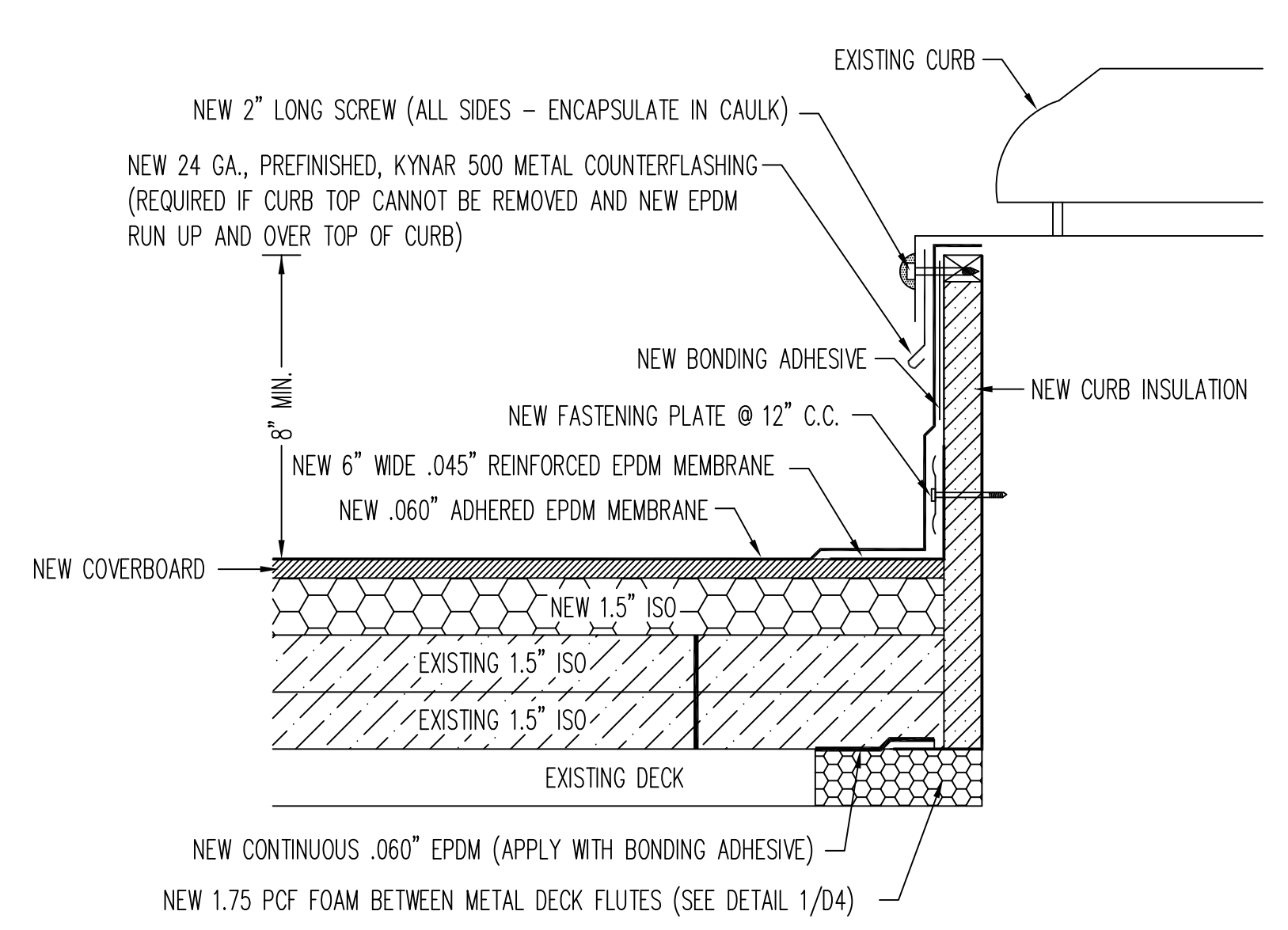

**4 CURB DETAIL**  
 SCALE: 3" = 1'-0"

NOT USED

DR: JAY	CK: RCR	PROJ. NO.: 2971	DATE: 5-1-23
WARREN-23 D2.DWG			REVISIONS
NO.	DATE	REMARKS	

**Richard C. Rinks & Associates, Inc.**  
 Engineering and Architectural Services  
 Building Enclosure Consultants  
 ASCE · NSPE · TSPE · IIBEC · EDI  
 30 North Jefferson Avenue (38501) P.O. Box 691 (38503)  
 Cookeville, Tennessee  
 Telephone 931-528-5543 Rinks-Consulting.com Facsimile 931-528-5544

ROOF REPLACEMENT  
 MIDDLE SCHOOL AUDITORIUM  
 McMinnville, Tennessee  
 FOR  
 WARREN COUNTY SCHOOLS  
 MAY 1, 2023  
 NEW ROOF DETAILS

SCALE: AS SHOWN

D2 SHEET 6 OF 8

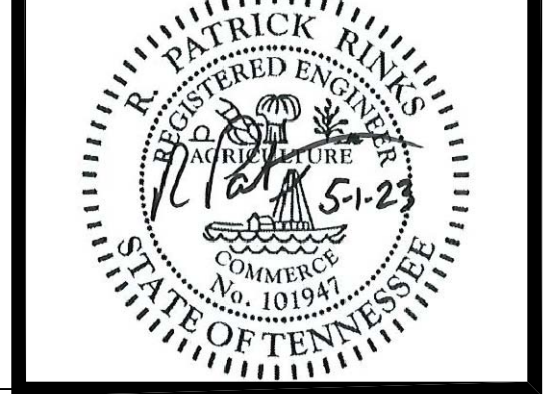





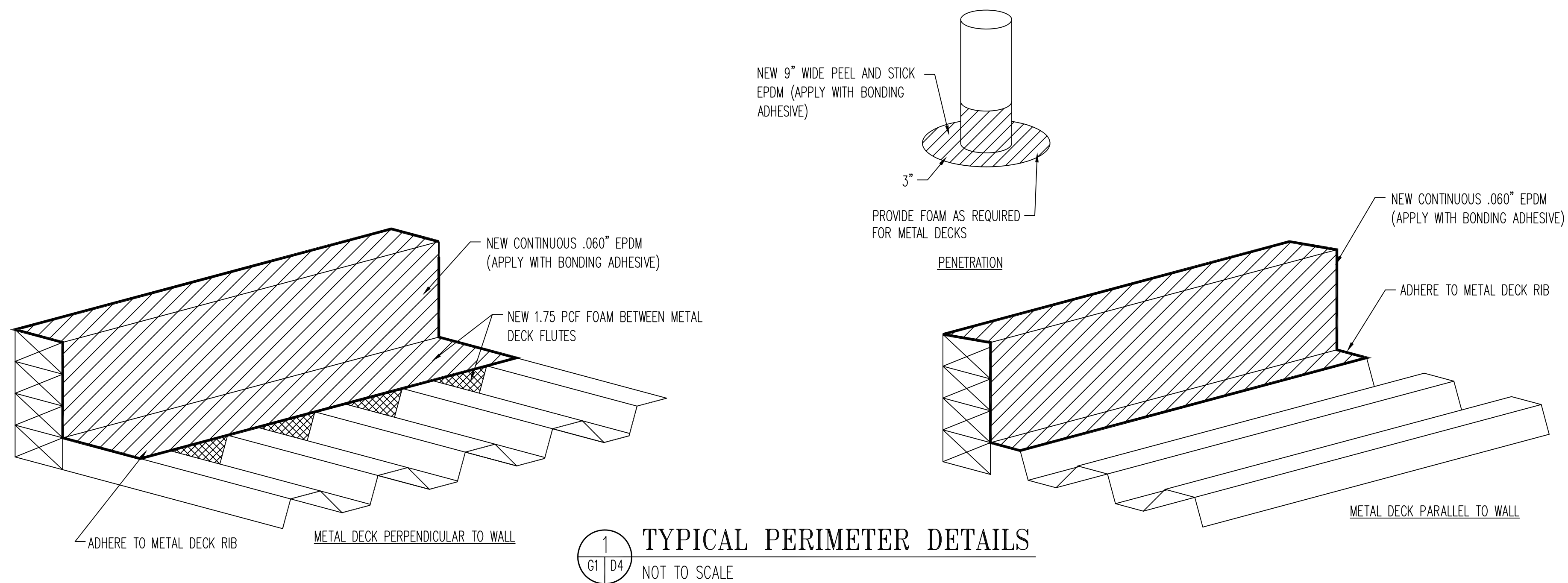

1 TYPICAL PERIMETER DETAILS  
G1 | D4 NOT TO SCALE

NOTES:  
1. GUTTER LENGTHS SHALL BE NO LONGER THAN 35'.  
2. ALL GUTTER JOINTS, IF ANY, SHALL BE COVERED WITH 5" AND 9" WIDE PEEL AND STICK EPDM. THIS INCLUDES ALL MITER JOINTS AT CORNERS.

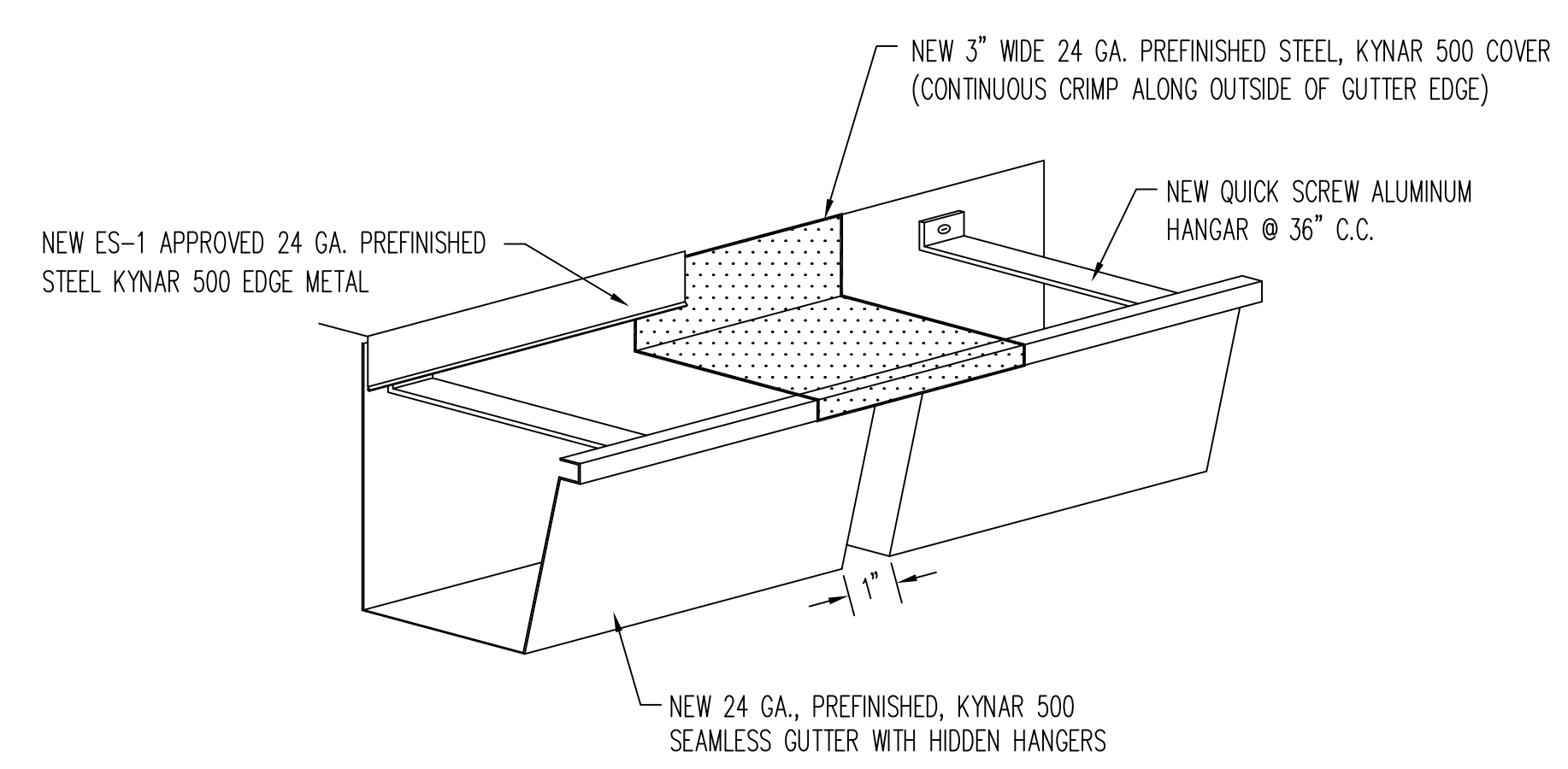

2 GUTTER EXPANSION DETAIL  
G1 | D4 SCALE: 3" = 1'-0"

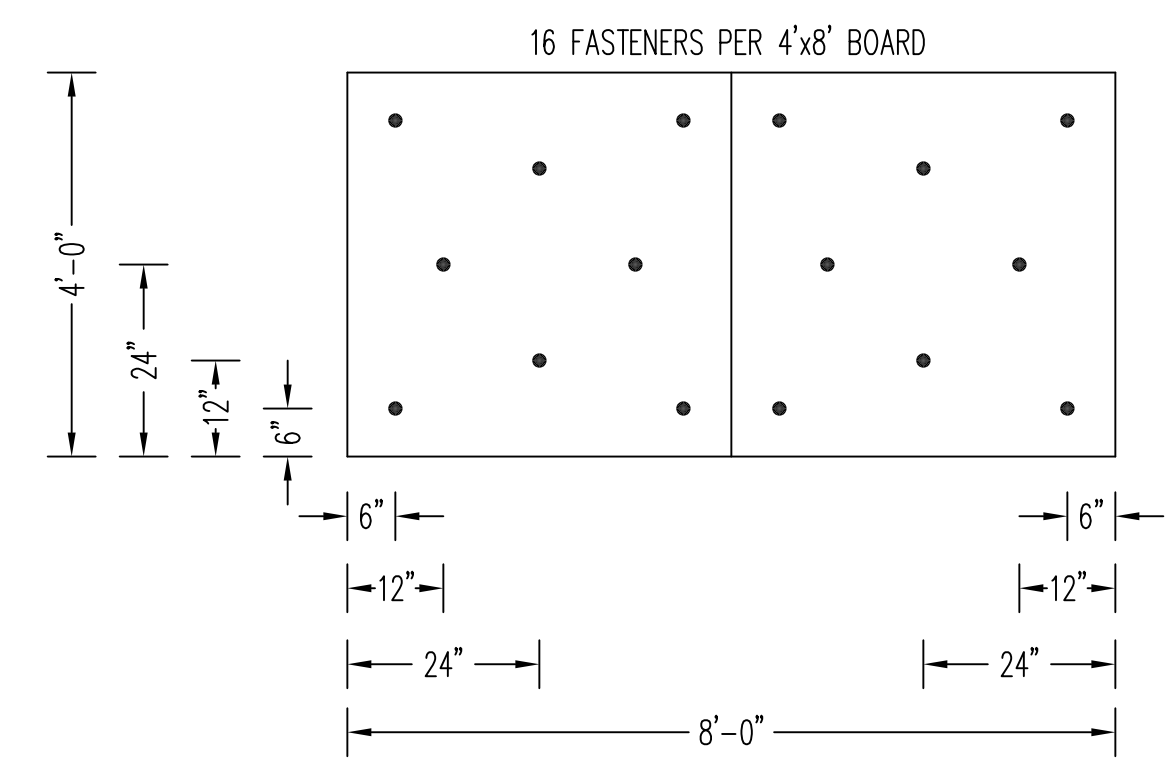

3 FIELD INSULATION FASTENER LAYOUT  
G1 | D4 NO SCALE

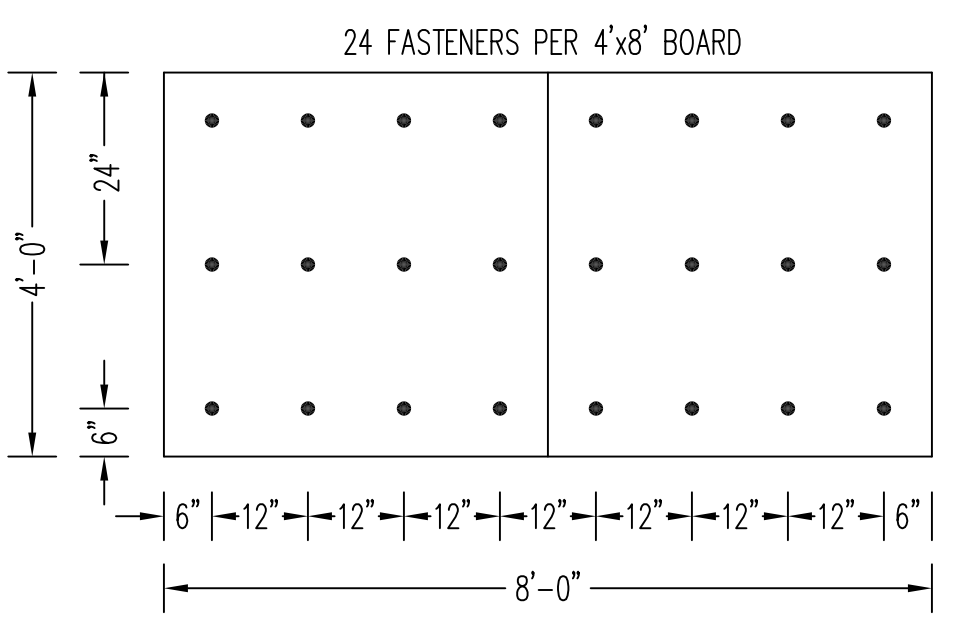

4 CORNER & PERIMETER INSULATION FASTENER LAYOUT  
G1 | D4 NO SCALE

NOTE:  
APPLY ADEQUATE FOAM AS SHOWN. ALLOW FOAM TO PROPERLY RISE BEFORE PLACING INSULATION IN FOAM. IMMEDIATELY PLACE FIVE FILLED FIVE GALLON BUCKETS ON ALL FOUR CORNERS AND MIDDLE OF EACH INSULATION BOARD. DO NOT REMOVE BUCKETS UNTIL FOAM HAS SET UP.  
USE MANUFACTURER'S RECOMMENDED SPACING FOR WIND RATING REQUIRED OR PATTERN SHOWN, WHICHEVER IS MORE STRINGENT.  
USE TEN FILLED 5 GALLON BUCKETS ON 4x8 BOARDS.  
SEE NEW ROOF PLAN FOR CORNERS AND PERIMETERS

FOAM SPACING "A"	
FIELD	4 EQUAL SPACES AT 11" C.C.
PERIMETERS	8 EQUAL SPACES AT 5.5" C.C.
CORNERS	11 EQUAL SPACES AT 4" C.C.

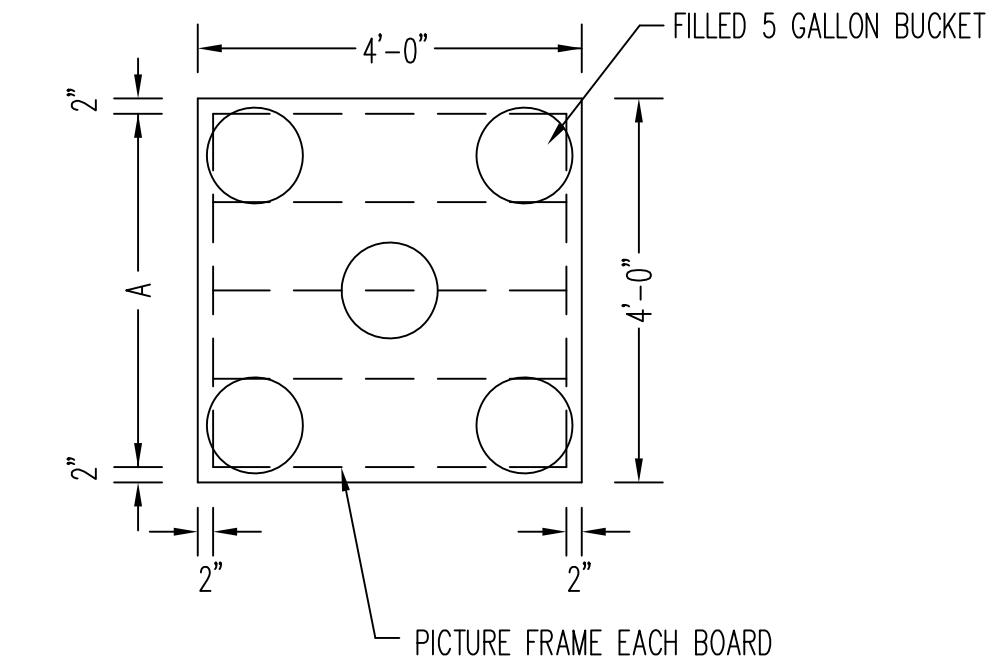

5 TYPICAL INSULATION ADHESIVE PATTERN  
G1 | D4 NO SCALE

NOTE:  
REUSE EXISTING SUPPORTS WHERE POSSIBLE. USE THIS DETAIL AS REQUIRED FOR ADDITIONAL SUPPORTS.

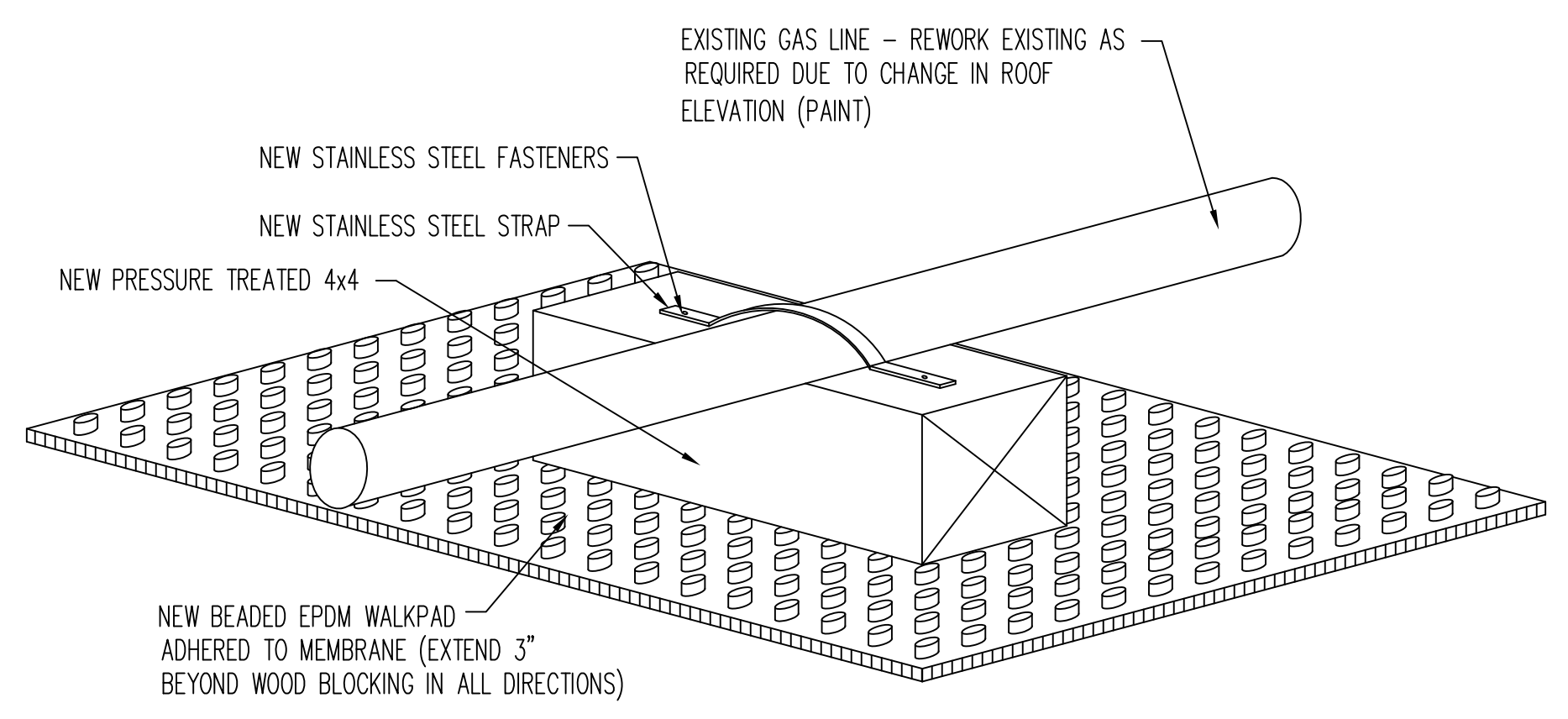

6 UTILITY LINE SUPPORT (AS REQUIRED)  
R2 | D4 NOT TO SCALE

NOT USED

NOT USED

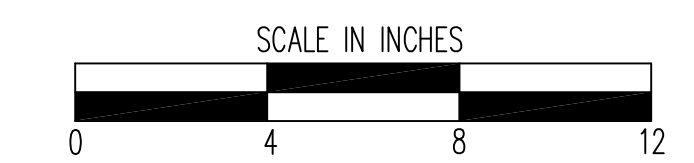

DR: JAY CK: ROR PROJ. NO.: 2971 DATE: 5-1-23  
WARREN-23 D4-DWG REVISIONS  
NO. DATE REMARKS

**Richard C. Rinks & Associates, Inc.**  
Engineering and Architectural Services  
Building Enclosure Consultants  
ASCE · NSPE · TSPE · IIBEC · EDI  
30 North Jefferson Avenue (38501) P.O. Box 691 (38503)  
Cookeville, Tennessee  
Telephone 931-528-5543 Rinks-Consulting.com Facsimile 931-528-5544

ROOF REPLACEMENT  
MIDDLE SCHOOL AUDITORIUM  
MCMINNVILLE, TENNESSEE  
FOR  
WARREN COUNTY SCHOOLS  
MAY 1, 2023  
NEW ROOF DETAILS

SCALE: AS SHOWN  
D4 SHEET 8 OF 8

